

HAFCO METALMASTER

TURRET MILLING MACHINE OPERATION MANUAL

**HM-51B****HM-54GB**

Models.

HM-51B, HM-54GB

Product Code M577, Product Code. M579

Edition No :TM-5154-1

Date of Issue :10/2019

www.machineryhouse.com.au



OPERATION MANUAL

MACHINE DETAILS

MACHINE

MODEL NO.

SERIAL NO.

DATE OF MANF.

Distributed by



www.machineryhouse.com.au
www.machineryhouse.co.nz

NOTE:

This manual is only for your reference. Owing to the continuous improvement of the HAFCO machines, changes may be made at any time without obligation or notice. Please ensure the local voltage is the same as listed on the specification plate before operating this electric machine.



NOTE:

In order to see the type and model of the machine, please see the specification plate. Usually found on the back of the machine. See example (Fig.1)

HAFCO
PRODUCT SPECIFICATION

MODEL:

CAPACITY:

SER. NO.:

MFG DATE:

WEIGHT:

VOLTS:

MOTOR Kw:

www.machineryhouse.com.au
Made in China

FIG.1



 OPERATION MANUAL

CONTENTS:

1. GENERAL MACHINE INFORMATION	
1.1 Specifications.....	4
1.2 Identification HM-51B.....	5
1.3 Identification HM-54GB.....	6
2. IMPORTANT INFORMATION	
2.1 General Metalworking Safe Practices.....	7
2.2 Safe Work Practices For Milling Machine.....	10
2.3 Lifting Instructions.....	11
3. SETUP	
3.1 Clean Up.....	12
3.2 Site Preparation.....	12
3.3 Machine Leveling.....	13
3.4 Electrical Installation.....	13
3.5 Full Load Current Rating.....	14
4. COMMISSIONING	
4.1 Basic Controls.....	14
4.2 Power Feed.....	17
4.3 Test Run.....	18
5. OPERATION	
5.1 Table Movements.....	20
5.2 Head Movements.....	21
5.3 Mounting The Tooling.....	23
5.4 Horizontal Setup (HM-54GV).....	24
5.5 Changing The Spindle Speeds.....	24
6. MAINTENANCE	
6.1 Lubrication Schedule.....	28
6.2 Gib Adjustment.....	29
6.3 Troubleshooting.....	30
SPARE PARTS.....	32
Risk Assessment.....	51

OPERATION MANUAL

1.1 SPECIFICATIONS

Product Code	M577	M579
Model	HM-51B	HM-54GV
Type	Vertical	Vertical/Horizontal
Table Size (mm)	1000 x 240	1000 x 240
Spindle Taper Horizontal	Nil	NT-30
Spindle Taper Vertical	NT-30	NT-30
Longitudinal Travel (X-Axis) (mm)	580	600
Cross Travel (Y-Axis) (mm)	190	200
Vertical Travel (Z-Axis) (mm)	350	340
Type of Slides	Dovetail	Dovetail
Ram Travel (mm)	350	450
Spindle to Table (mm)	390	375
Spindle Travel / Diameter (mm)	125/90	125/90
Throat Depth (max.) (mm)	550	640
Tilting Head (Left ~ Right)	±90 °	±45 °
Tilting Head (Forward ~ Back)	Fixed	Fixed
Drilling Capacity (mm)	30	40
End Milling Capacity (mm)	25	25
Face Milling Capacity (mm)	80	80
Power Feed - Quill (mm/rev)	Manual	Manual
Power Feed - Longitudinal (X-Axis) (mm/min)	20 - 2000	20 - 2000
Power Feed - Cross (Y-Axis) (mm/min)	Optional	Optional
Power Feed - Vertical (Z-Axis) (mm/min)	Optional	Optional
Table T-Slot Size (mm)	14	14
Work Table Load Capacity (kg)	175	160
Work Table Swivel (LH/RH)	30 °/40 °	30 °/40 °
Spindle Speeds Vertical (no/rpm)	9 (220 - 2400)	Variable (100 - 2000)
Spindle Speeds Horizontal (no/rpm)	Nil	9 (60 - 1350)
Motor Power - Vertical (kW/hp)	2.2 / 3	2.2 / 3
Motor Power - Horizontal (kW/hp)	Nil	1.5 / 2
Voltage / Amperage (V/amp)	240/15	240/15
Dimensions (L x W x H) (mm)	138 x 140 x 210	138 x 150 x 215
Shipping Dimensions (L x W x H) (mm)	134 x 114 x 227	134 x 114 x 225
Weight (kg)	850	900

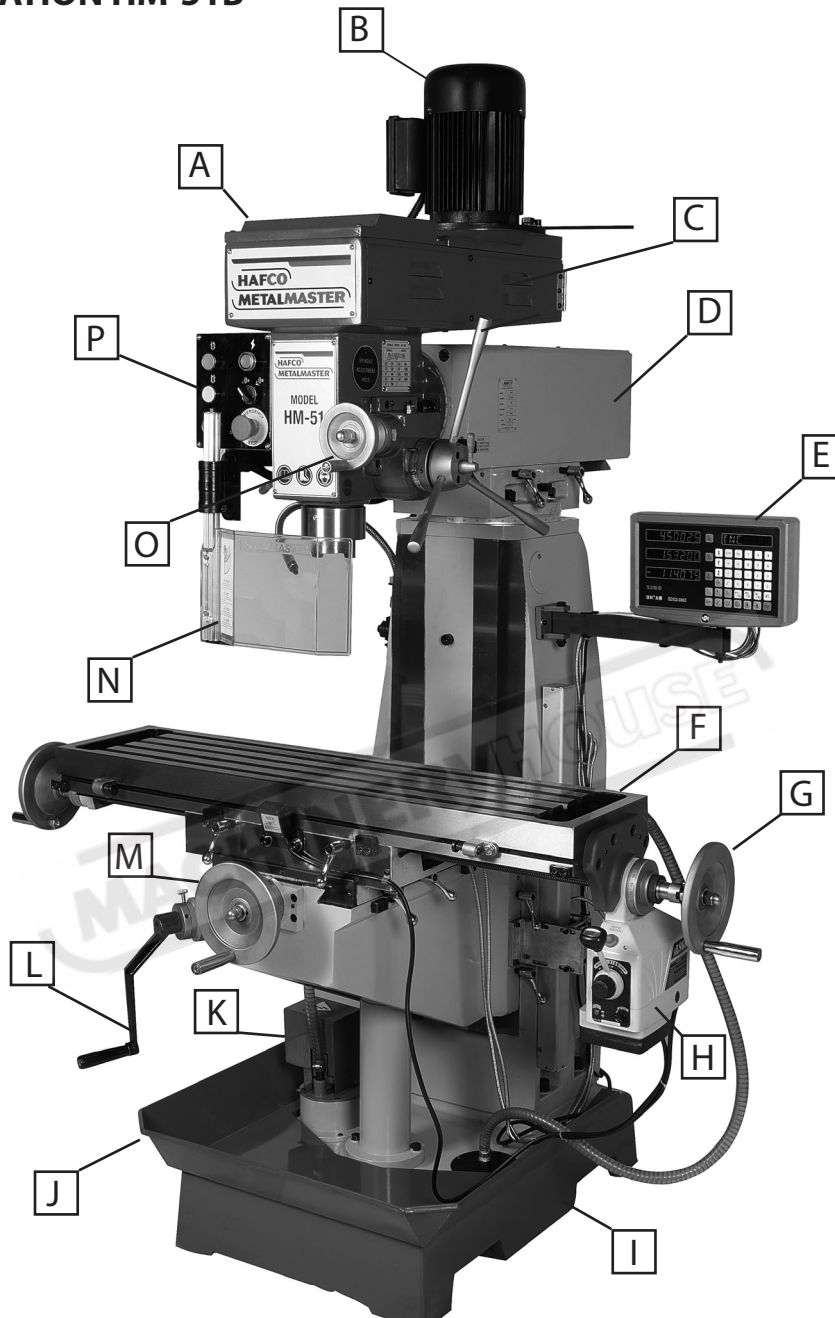
1.2 IDENTIFICATION HM-51B

A	HEAD	I	BASE
B	MOTOR	J	SPLASH TRAY
C	BELT DRIVE COVER	K	COOLANT PUMP
D	RAM	L	"Z" AXIS HANDLE
E	DIGITAL READOUT	M	"Y" AXIS HANDLE
F	TABLE	N	SPINDLE GUARD
G	"X" AXIS HAND-WHEEL	O	SPINDLE FINE FEED HAND-WHEEL
H	POWER FEED UNIT	P	CONTROL PANEL

1.3 IDENTIFICATION HM-54GB

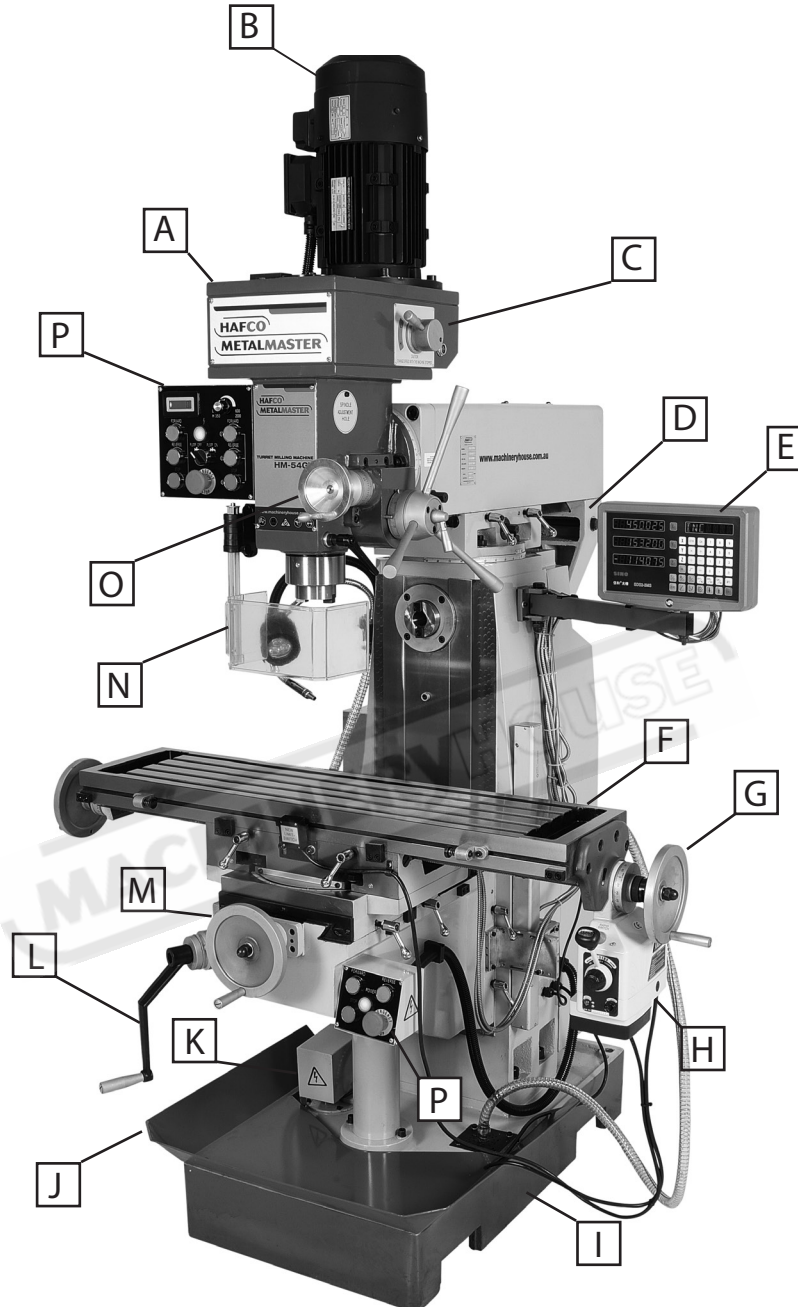

A	HEAD	I	BASE
B	MOTOR	J	SPLASH TRAY
C	VARIABLE SPEED SELECTOR	K	COOLANT PUMP
D	HORIZONTAL ARBOR SUPPORT	L	"Z" AXIS HANDLE
E	DIGITAL READOUT	M	"Y" AXIS HANDLE
F	TABLE	N	SPINDLE GUARD
G	"X" AXIS HAND-WHEEL	O	SPINDLE FINE FEED HAND-WHEEL
H	POWER FEED UNIT	P	2 X CONTROL PANELS

2.1 GENERAL METALWORKING SAFE PRACTICES

DO NOT use this machine unless you have read this manual or have been instructed in the use of this machine in its safe use and operation



WARNING

This manual provides safety instructions on the proper setup, operation, maintenance, and service of this machine. Save this manual, refer to it often, and use it to instruct other operators. Failure to read, understand and follow the instructions in this manual may result in fire or serious personal injury—including amputation, electrocution, or death.

The owner of this machine is solely responsible for its safe use. This responsibility includes, but is not limited to proper installation in a safe environment, personnel training and authorization to use, proper inspection and maintenance, manual availability and comprehension, of the application of the safety devices, integrity, and the use of personal protective equipment.

The manufacturer will not be held liable for injury or property damage from negligence, improper training, machine modifications or misuse.



- ✓ Always wear safety glasses or goggles.
- ✓ Wear appropriate safety footwear.
- ✓ Wear respiratory protection where required.
- ✓ Gloves should never be worn while operating the machine, and only worn when handling the workpiece.
- ✓ Wear hearing protection in areas > 85 dBA. If you have trouble hearing someone speak from one metre (three feet) away, the noise level from the machine may be hazardous.
- ✓ DISCONNECT THE MACHINE FROM POWER when making adjustments or servicing.
- ✓ Check and adjust all safety devices before each job.
- ✓ Ensure that guards are in position and in good working condition before operating.
- ✓ Ensure that all stationary equipment is anchored securely to the floor.
- ✓ Ensure all machines have a start/stop button within easy reach of the operator.
- ✓ Each machine should have only one operator at a time. However, everyone should know how to stop the machine in an emergency.

2.1 GENERAL METALWORKING SAFE PRACTICES Cont.

- ✓ Ensure that keys and adjusting wrenches have been removed from the machine before turning on the power. Appropriate storage for tooling should be provided.
- ✓ Ensure that all cutting tools and blades are clean and sharp. They should be able to cut freely without being forced.
- ✓ Stop the machine before measuring, cleaning or making any adjustments.
- ✓ Wait until the machine has stopped to clear cuttings with a vacuum, brush or rake.
- ✓ Keep hands away from the cutting head and all moving parts.
- ✓ Avoid awkward operations and hand positions. A sudden slip could cause the hand to move into the cutting tool or blade.
- ✓ Return all portable tooling to their proper storage place after use.
- ✓ Clean all tools after use.
- ✓ Keep work area clean. Floors should be level and have a non-slip surface.
- ✓ Use good lighting so that the work piece, cutting blades, and machine controls can be seen clearly. Position or shade lighting sources so that they do not cause any glare or reflections.
- ✓ Ensure there is enough room around the machine to do the job safely.
- ✓ Obtain first aid immediately for all injuries.
- ✓ Understand that the health and fire hazards can vary from material to material. Make sure all appropriate precautions are taken.
- ✓ Clean machines and the surrounding area when the operation is finished.
- ✓ Use proper lock out procedures when servicing or cleaning the machines or power tools.
- ✓ Do not distract an operator. Horseplay can lead to injuries and should be strictly prohibited.
- ✓ Do not wear loose clothing, gloves, necktie's, rings, bracelets or other jewellery that can become entangled in moving parts. Confine long hair.
- ✓ Do not handle cuttings by hand because they are very sharp. Do not free a stalled cutter without turning the power off first. Do not clean hands with cutting fluids.
- ✓ Do not use rags near moving parts of machines.
- ✓ Do not use compressed air to blow debris from machines or to clean dirt from clothes.

DO NOT

- × Do not distract an operator. Horseplay can lead to injuries and should be strictly prohibited.
- × Do not wear loose clothing, gloves, necktie's, rings, bracelets or other jewellery that can become entangled in moving parts. Confine long hair.
- × Do not handle cuttings by hand because they are very sharp. Do not free a stalled cutter without turning the power off first. Do not clean hands with cutting fluids.
- × Do not use rags or wear gloves near moving parts of machines.
- × Do not use compressed air to blow debris from machines or to clean dirt from clothes.
- × Do not force the machine. It will do the job safer and better at the rate for which it was designed.

2.1 GENERAL METALWORKING SAFE PRACTICES Cont.

HAZARDS ASSOCIATED WITH MACHINES include, but are not limited to:

- Being struck by ejected parts of the machinery
- Being struck by material ejected from the machinery
- Contact or entanglement with the machinery
- Contact or entanglement with any material in motion

Health Hazards (other than physical injury caused by moving parts)

- Chemicals hazards that can irritate, burn, or pass through the skin
- Airborne items that can be inhaled, such as oil mist, metal fumes, solvents, and dust
- Heat, noise, and vibration
- Ionizing or non-ionizing radiation (X-ray, lasers, etc.)
- Biological contamination and waste
- Soft tissue injuries (for example, to the hands, arms, shoulders, back, or neck) resulting from repetitive motion, awkward posture, extended lifting, and pressure grip)

Other Hazards

- Slips and falls from and around machinery during maintenance
- Unstable equipment that is not secured against falling over
- Safe access to/from machines (access, egress)
- Fire or explosion
- Pressure injection injuries from the release of fluids and gases under high pressure
- Electrical Hazards, such as electrocution from faulty or ungrounded electrical components
- Environment in which the machine is used (in a machine shop, or in a work site)

WARNING

Machines are safeguarded to protect the operator from injury or death with the placement of guards. Machines must not be operated with the guards removed or damaged.

2.2 SAFE WORK PRACTICES FOR MILLING MACHINE

DO NOT use this machine unless you have been instructed in its safe use and operation and have read and understand this manual



Safety glasses must be worn at all times in work areas.



Long and loose hair must be contained.



Gloves must not be worn when using this machine



Sturdy footwear must be worn at all times in work areas



Close fitting/protective clothing must be worn.



Rings and jewellery must not be worn.

PRE-OPERATIONAL SAFETY CHECKS

- Locate and ensure you are familiar with all machine operations and controls.
- Ensure all guards are fitted, secure and functional. Do not operate if guards are missing or faulty.
- Check workspaces and walkways to ensure no slip/trip hazards are present.
- Ensure cutter is in good condition and securely mounted.
- Check coolant delivery system to allow for sufficient flow of coolant.

OPERATIONAL SAFETY CHECKS

- Keep clear of moving machine parts.
- Follow correct clamping procedures. Keep overhangs as small as possible and check the workpiece is secure.
- Set the correct speed to suit the material, cutter diameter, the depth of cut

ENDING OPERATIONS AND CLEANING UP

- Switch off the machine when work completed.
- Remove milling cutters and store them safely.
- Before making adjustments and measurements or cleaning swarf accumulations, Switch off and bring the machine to a complete standstill.
- Leave the machine and work area in a safe, clean and tidy state.

POTENTIAL HAZARDS AND INJURIES

- Sharp cutters.
- Hair/clothing caught in moving parts.
- Eye injuries.
- Skin irritation.
- Metal splinters and burrs.
- Flying debris.

DON'T

- Do not use faulty equipment. Immediately report suspect machinery.
- Never leave the machine running unattended.
- Do not leave equipment on top of the machine.

2.3 LIFTING INSTRUCTIONS

On the day that the machine arrives, make sure that a crane with sufficient capacity is available to unload the machine from the vehicle. Ensure access to the chosen site is clear and that doors and ceilings are sufficiently high and wide enough to receive the machine.

To handle the machine, the straps should be positioned so the machine is level when lifted.

When using straps please take note of the strap angle and the loads that apply

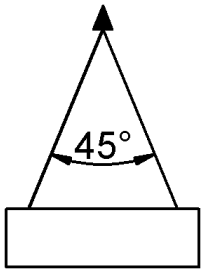

FIG 2.1.

When the straps are at a 45° angle then each strap is carrying the equivalent of 50% of load weight. (Fig.2.1).

When the straps are at a 90° angle then each strap will have a weight equal to 75% of the load on each strap. (Fig 2.2)

Note! The manufacturer recommends not to exceed 90° angle

FIG 2.2

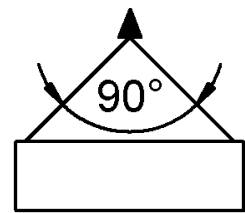

LIFTING POINTS

When lifting the machine only certified lifting straps should be used.

Ensure that when lifting, the machine does not tip over. Check that the lifting straps do not interfere with the hydraulic pipes or electrical conduits.

Failure to follow these instructions could cause damage to the machine.

To lift the machine

1. Rotate ram 180° clockwise so the headstock faces backwards
2. Tighten the four turret lock bolts (two on each side of ram, as shown in Fig.2.3). This will help keep the ram from unexpectedly moving from the force of the lifting straps.

Note: Place protective material between the straps and mill to protect the ram and ways, and to prevent cutting the lifting straps.

3. Place lifting straps under ram and connect to a safety hook, (Fig. 2.4)
4. With other people steadying load to keep it from swaying, lift machine a couple of centimeters. — If mill tips to one side, lower it to the pallet and adjust ram or table to balance load. Make sure to re-tighten lock levers and bolts before lifting mill again.

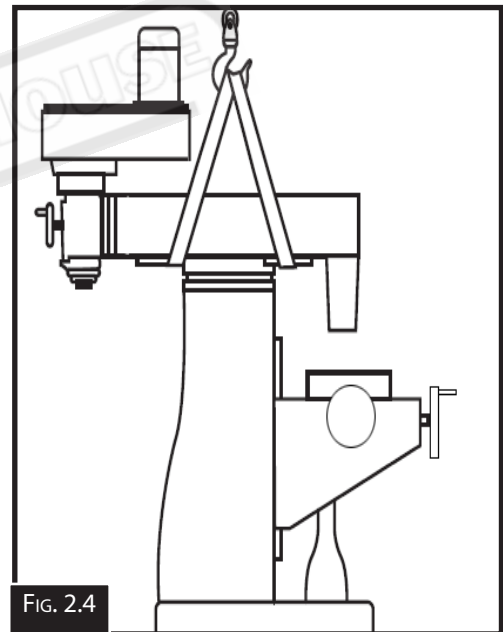

FIG. 2.4

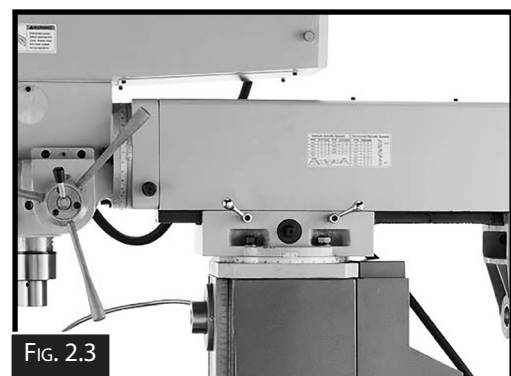

FIG. 2.3

3. SETUP

3.1 CLEAN - UP

The unpainted surfaces of the machine have been coated with a waxy oil to protect them from corrosion during shipment. Remove the protective coating with a solvent cleaner or a citrus based degreaser.

Optimum performance from your machine will be achieved when you clean all moving parts or sliding contact surfaces that are coated with rust prevented products.

It is advised to avoid chlorine based solvents, such as acetone or brake parts cleaner, as they will damage painted surfaces and strip metal should they come in contact. Always follow the manufacturer's instructions when using any type of cleaning product.

3.2 SITE PREPARATION

When selecting the site for the machine, consider the largest size of workpiece that will be processed through the machine and provide enough space around the machine for operating the machine safely. Consideration should be given to the installation of auxiliary equipment. Leave enough space around the machine to open or remove doors/covers as required for the maintenance and service as described in this manual.

It is recommended that the machine is anchored to the floor to prevent tipping or shifting. It also reduces vibration that may occur during operation.

OPTIONS FOR MOUNTING

The machine is best mounted on a concrete slab.

Masonry anchors with bolts are the best way to anchor machinery, because the anchors sit flush with the floor surface, making it easy to unbolt and move the machine later, if needed. (Fig. 3.1)

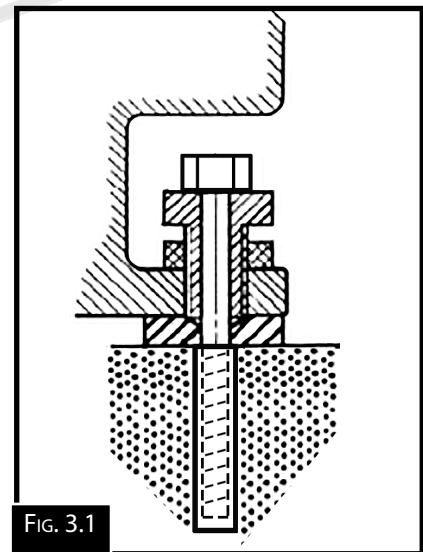

FIG. 3.1

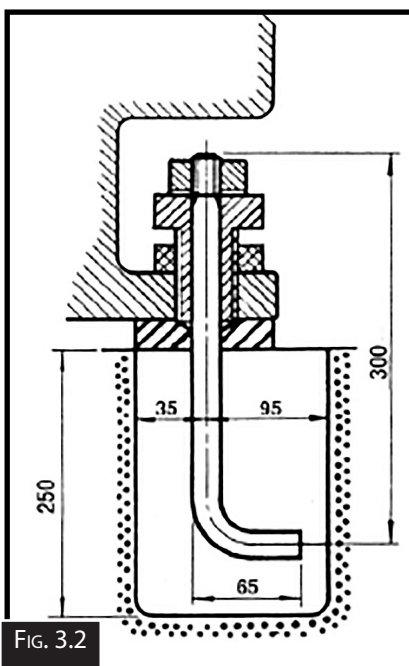

FIG. 3.2

In some case a suitable foundation may not be available and a new one may need to be prepared. The foundation should be concrete approximately 300mm thick with pockets left clear for the hold down bolts.. The hold down bolts can be "L" shape as per the example in Fig. 3.2



OPERATION MANUAL

3.3 MACHINE LEVELING

To set your machine up so that it operates to optimum performance, apply the following procedure

After your machine has been anchored to a concrete slab floor, it then needs to be leveled. Loosen the hold down bolts and place a level on the surface of the working table. Metal shims need to be placed under the corners of the base of the machine until level. Once level then tighten the hold down bolts. (Fig. 3.1).

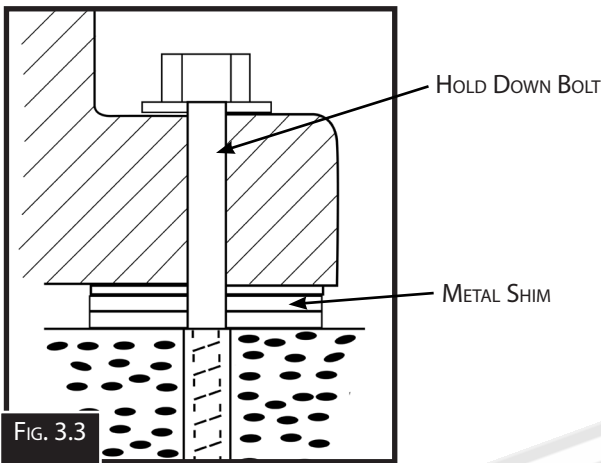

The machine must not rest on supports other than those defined in Fig. 3.2 & Fig.3.3



3.4 ELECTRICAL INSTALLATION

Place the machine near an existing power source. Make sure all power cords are protected from traffic, material handling, moisture, chemicals, or other hazards. Make sure there is access to a means of disconnecting the power source. The electrical circuit must meet the requirements for 240V. To minimize the risk of electrocution, fire, or equipment damage, these machines should be plugged directly into the socket, or hard wired with the installation work and electrical wiring done by a qualified electrician.

NOTE : The use of an extension cord is not recommended as it may decrease the life of electrical components on your machine.

ELECTRICAL REQUIREMENTS

Nominal Voltage.....	240V
Cycle.....	50 Hz
Phase.....	Single Phase
Power Supply Circuit.....	15 Amps
Full Load Current.....	13.6 Amps

(Full load current rating is also on the specification plate on the motor.)

3.5 FULL-LOAD CURRENT RATING

The full-load current rating is the amperage a machine draws when running at 100% of the output power. Where machines have more than one motor, the full load current is the amperage drawn by the largest motor or a total of all the motors and electrical devices that might operate at one time during normal operations.

Full-Load Current Rating for these machine at 240V is 13.6 Amps

It should be noted that the full-load current is not the maximum amount of amps that the machine will draw. If the machine is overloaded, it will draw additional amps beyond the full-load rating and if the machine is overloaded for a long period of time, damage, overheating, or fire may be caused to the motor and circuitry.

This is especially true if connected to an undersized circuit or a long extension lead. To reduce the risk of these hazards, avoid overloading the machine during operation and make sure it is connected to a power supply circuit that meets the requirements.



4. COMMISSIONING

4.1 BASIC CONTROLS

The following descriptions are supplied to give the help the operator develop an understanding of the basic controls used to operate the milling machine. This knowledge will be necessary to safely complete the Test Run later in this manual.

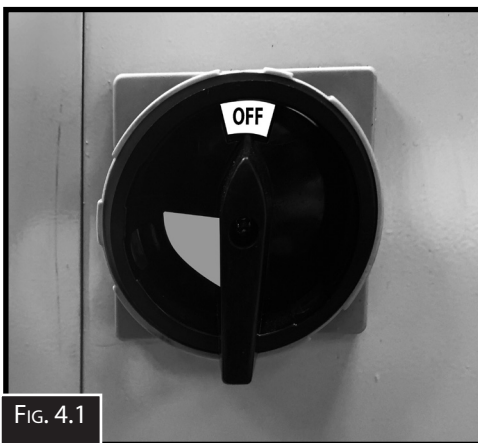

FIG. 4.1

Isolating Power Switch: The switch is found on the electrical control box mounted on the side of the machine. The switch enables power to flow to the machine when the "ON" is visible at the top of the switch.

4.1 BASIC CONTROLS CONT. HM-54GV

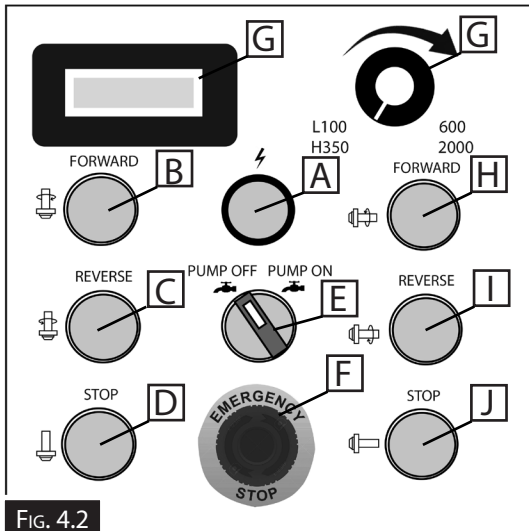

FIG. 4.2

- A. Power Lamp Button:** When pressed, illuminates and enables power to both control panels. Both Emergency STOP buttons must be reset first.
- B. Forward Button (Vertical Spindle):** Starts vertical spindle forward rotation (clockwise looking down on the headstock).
- C. Reverse Button (Vertical Spindle):** Starts vertical spindle reverse rotation (counterclockwise looking down on the headstock).
- D. STOP Button (Vertical Spindle):** Stops vertical spindle rotation.
- E. Coolant Switch:** Turns ON or OFF the coolant pump
- F. Emergency STOP Button:** Disables power to both control panels and stops all machine functions. To reset, twist the button clockwise until it pops out.

- G. Rotary Speed Control Knob and Display:** Controls the speed of the vertical spindle and displays the RPM on the display.
- H. Forward Button (Horizontal Spindle):** Starts the horizontal spindle in a forward rotation (clockwise when facing the spindle).
- I. Reverse Button (Horizontal Spindle):** Starts horizontal spindle in a reverse rotation (anti-clockwise when facing the spindle).
- J. STOP Button (Horizontal Spindle):** Stops the horizontal spindle rotation

CONTROLS ON THE KNEE

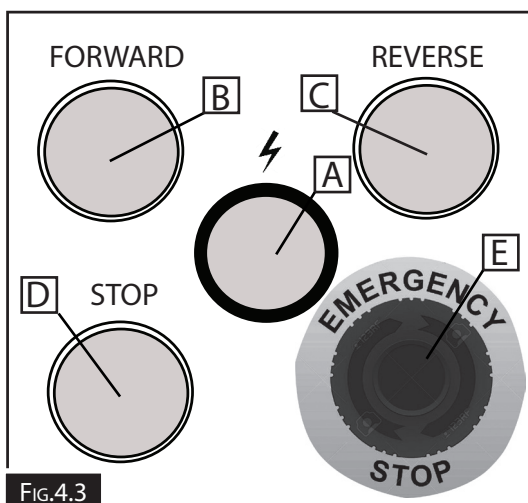

FIG.4.3

- A. Power Lamp Button:** When it is illuminated it enables power to the control panel. The Emergency STOP buttons must be reset first.
- B. Forward Button:** Starts the horizontal spindle in a forward rotation (clockwise when facing the spindle).
- C. Reverse Button:** Starts the horizontal spindle in a reverse rotation (counterclockwise when facing the spindle).
- D. STOP Button:** Stops the spindle rotation.
- E. Emergency STOP Button:** Disables power to the control panel and stops all machine functions. To reset, twist the button clockwise until it pops out.

4.1 BASIC CONTROLS CONT.

HM-54GV

Hi/Low Speed Selector: Selects the speed range for either HIGH or LOW.

NOTE: The lever must only be changed when the spindle is stopped.

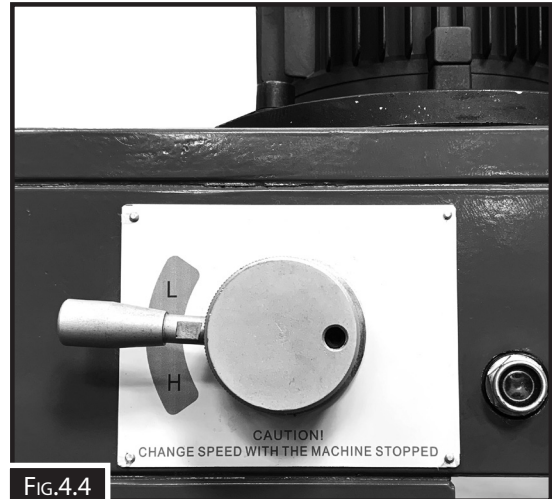

FIG.4.4

HM-51B

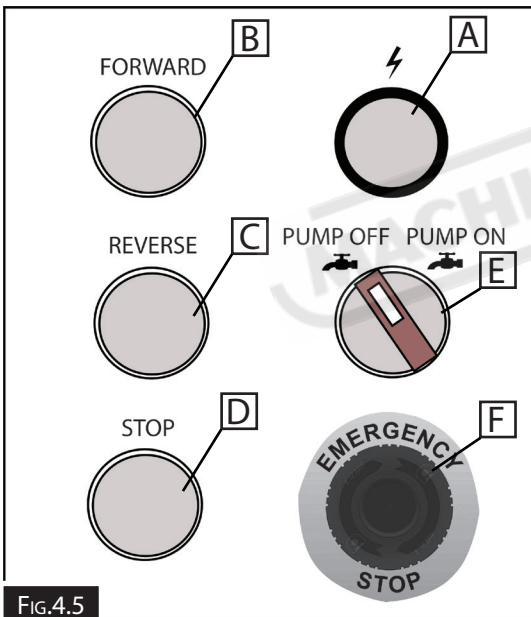

FIG.4.5

- A. Power Lamp Button:** When pressed, illuminates and enables power to the control panel. The Emergency Stop buttons must be reset first.
- B. Forward Button:** Starts the spindle in a forward rotation (clockwise looking down on the head).
- C. Reverse Button:** Starts the spindle reverse rotation (counterclockwise looking down on the head).
- D. Stop Button:** Stops the spindle rotation.
- E. Coolant Switch:** Turns ON or OFF the coolant pump
- F. Emergency Stop Button:** Disables power to the control panel and stops all machine functions. To reset, twist the button clockwise until it pops out.

4.2 POWER FEED UNIT

A. Directional Lever: Selects the direction of table movement. The center position is neutral.

B. Rapid Traverse Button: Once the directional lever has been activated, causes the table to travel at full speed while pushed.

C. Speed Dial: Controls the speed of table movement. Turning the dial clockwise causes the table to move faster.

Note: Feed rates for table travel are extremely difficult to precisely calculate. We recommend that you combine research and experimentation to find the feed rates that best work for your operations.

D. ON/OFF Switch: Enables/disables power to the unit.

E. Reset Button: Resets the internal circuit breaker if the unit is overloaded and shuts down..

F. Limit Switch: Stops powered table movement when either of the side plungers come in contact with the limit stops.

G. Limit Stop: Limits X-axis table travel (one on either end of the table).

H. Graduated Dial: Displays X-axis table movement in 0.02mm increments, with each revolution equaling 4mm of travel.

I. Handwheel: Manually positions the table.

J. Table Locks: Locks the table when in position.

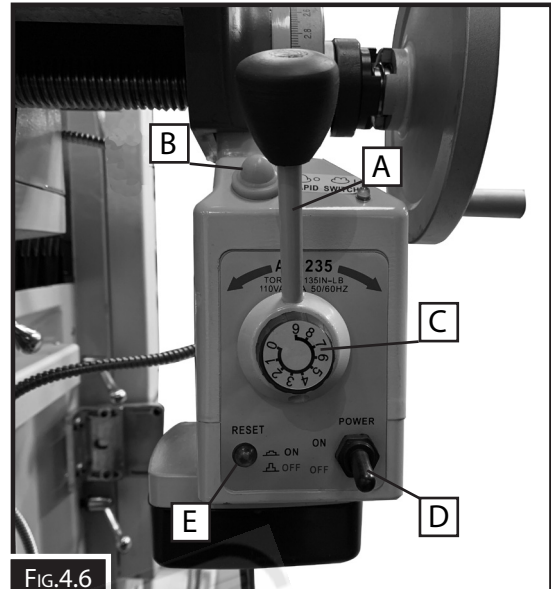

FIG.4.6

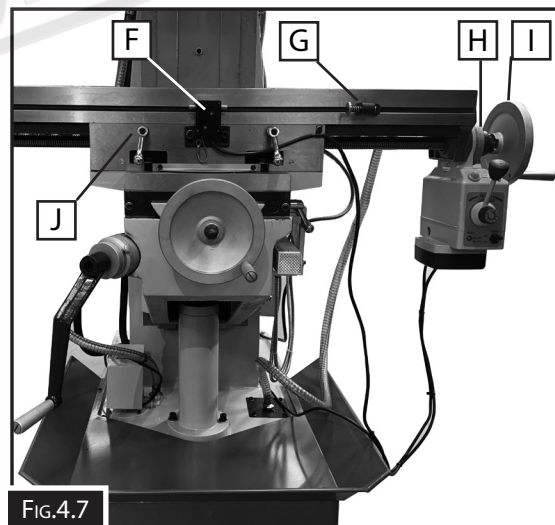

FIG.4.7



The table stops **MUST** be loosened before the table feed is used. Failure to do so may cause damage to the gears in the powerfeed unit.

4.3 TEST RUN

Once assembly is complete, the machine needs a test run to ensure it is connected properly to power and functions correctly. During the test run, checks need to be made to the the proper operation of the spindle, motors, the Emergency Stop buttons, and the power feed unit. If any unusual problem is found during the test run, immediately stop the machine, disconnect it from the power supply, and fix the problem before operating the machine again. For possible answers, refer to the The Troubleshooting table in the Maintenance section of this manual for help.

How To Test Run

1. Read and follow the safety instructions at the beginning of the manual, take required safety precautions, and make sure the machine is set up and adjusted correctly.
2. Clear away all tools and objects used during assembly and preparation.
3. Make sure mill is properly lubricated (refer to Lubrication section beginning on Page 28 for specific details).
4. (HM-51B) Position vertical spindle V-belts for 220 RPM. Refer to Changing The Spindle Speed, beginning on Page 25 for detailed instructions). (HM-54GV). Adjust the variable spindle speed to 220rpm and horizontal spindle V-belts for 72 RPM (See details on page 26)
5. Push the Emergency Stop buttons to avoid unexpected start up when machine is connected to power.
6. Connect mill to power source specified on Page 13
7. Turn power isolation switch ON.
8. Twist the Emergency Stop buttons clockwise until they pop out—this resets them for operation (see Fig.4.8).
9. Press Power Lamp button on master control panel to enable power to the control panels—the button should illuminate.
10. Start vertical spindle forward rotation.
11. Listen for abnormal noises and watch for anything unexpected from the mill. The mill should run smoothly and without excessive vibration or rubbing noises. Strange or unusual noises or actions must be investigated immediately. Turn the machine OFF and disconnect it from the power source before investigating or correcting potential problems.
12. Stop spindle rotation and wait for spindle to completely stop.
13. Repeat Steps 11–12 with vertical spindle reverse rotation.
14. **(HM-54GV Only)** Repeat Steps 10–12 with horizontal spindle.
15. Press Emergency Stop button on master control panel.
16. Without resetting the Emergency Stop button, attempt to start vertical spindle rotation. The machine should not start. If the machine does start (with the Emergency Stop button pushed in), immediately disconnect power to the machine. The Emergency Stop button safety feature is not working correctly. This safety feature must work properly before proceeding with regular operations. Call your local distributor for help.
17. Reset Emergency Stop button.
18. **(HM-54GV Only)** Repeat Steps 15–17 with horizontal spindle control sub-panel and horizontal spindle



FIG.4.8

4.3 SETUP CONT.

Power Feed Test Run:

The mill comes with a power feed unit for X-axis table travel. Proper operation of the limit switch attached in the middle of the table at the front, is critical for the safe use of this power feed unit. If the power feed does not operate as expected during the following steps, disconnect it from power and contact your local distributor

To test the power feed:

1. Make sure all tools, cables, and other items are well clear of table movement as you follow these steps.
2. Refer to Power Feed identification on Page 17, to understand how power feed, table locks, and limit switch function.
3. Move the limit stops so they are within 100mm of the limit switch and tighten.
4. Loosen table locks on the front of table. Make sure power feed directional lever is in neutral (middle) position, turn speed dial counterclockwise to lowest setting, then turn power feed ON.
5. Move direction knob to the left, slowly rotate speed dial clockwise to increase speed, then confirm table is moving left.
6. Watch for table limit stop to hit the limit switch which will turn the power feed OFF, stopping table movement.
7. Move direction knob through the neutral (middle) position and all the way right. Table should begin moving right.
8. Confirm the table stops moving when limit stop presses against limit switch plunger.
9. Move direction knob to the neutral (middle) position, turn speed dial counterclockwise to lowest setting, and turn power feed OFF

5. OPERATION

The purpose of this overview is to provide the novice machine operator with a basic understanding of how the machine is used during operation, so the machine controls/components discussed later in this manual are easier to understand.

Due to the generic nature of this overview, it is not intended to be an instructional guide. To learn more about specific operations, read this entire manual and seek additional training from experienced machine operators, and do additional research outside of this manual by reading "how-to" books, trade magazines, or visiting instructional websites.

To complete a typical operation, the operator should do the following

1. Examines the workpiece to make sure it is suitable for the operation.
2. Firmly clamp the workpiece to the table or hold the workpiece in a mill vise.
3. Install the correct cutting tool for the operation.
4. Use the downfeed and table controls to correctly position the cutting tool and workpiece for the operation. If the X-axis power feed is to be used during the operation, the operator must confirm the speed and length of the table movement required.
5. Configure the machine for the correct spindle speed, and if coolant is to be used for the operation.
6. The operator must put on personal protective gear, and make sure the workpiece and table are clear of all tools, cords, and other items.
7. Start the spindle rotation and perform the operation.
8. Turn the machine OFF.

5.1 TABLE MOVEMENTS

The mill table travels in three directions, as illustrated in Fig. 5.1

These movements are controlled by table handwheels and the Z-axis crank. Additionally, the table can be moved along the X-axis with the power feed and rotated 45° left and right.

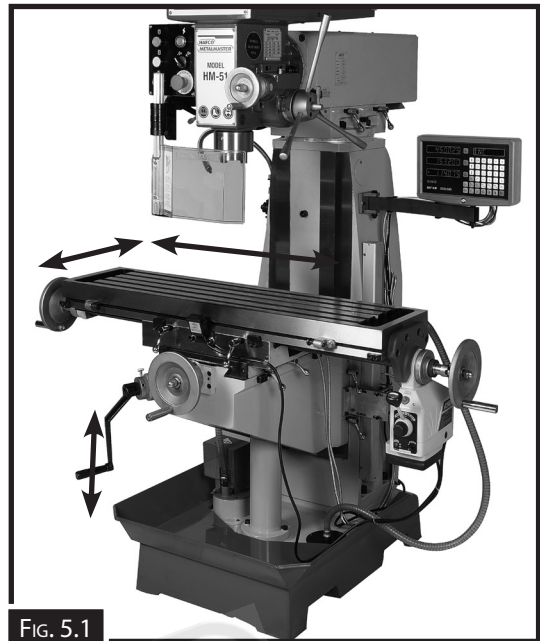

FIG. 5.1

GRADUATED INDEX RINGS

The table handwheels and knee crank have graduated rings (see Fig. 5.2) that are used to determine table movement in 0.02mm increments. Additionally, each dial has a thumbscrew that is used to adjust the dial to zero.



FIG. 5.2

TABLE LOCKS

Use table locks to increase the rigidity of the table when movement in that direction is not required for the operation.

Refer to Fig. 5.3 to identify the locks for each table axis.

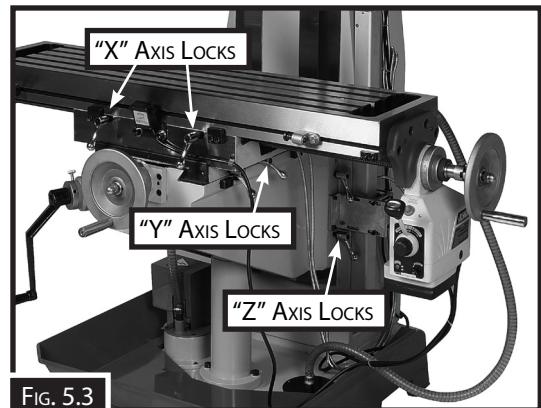

FIG. 5.3

TABLE ROTATION

The table rotates 45° left or right (Fig.5.4)

To rotate the table:

1. DISCONNECT MACHINE FROM POWER!
 2. Remove as many items from table as possible. This makes rotating the table easier.
 3. Loosen the four hex nuts that secure table to knee (see Fig. 5.4).
- Note:** There are two hex nuts behind the table as well.
4. Using the angle scale on knee as a guide, rotate the table to desired position.
 5. Retighten the four hex nuts that secure the table to knee before resuming operation.

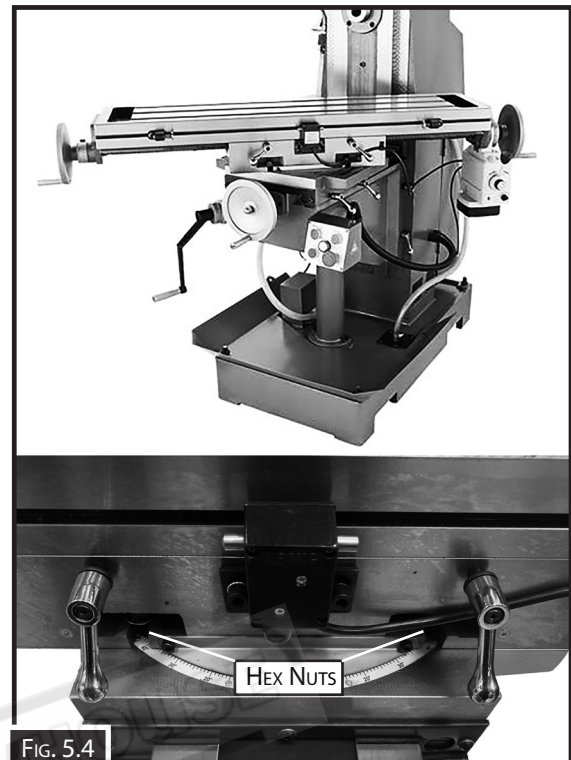

Fig. 5.4

5.2 HEAD MOVEMENTS

HEAD TILT

(HM-51B) The head tilts 90° left or right at the end of the ram.

(HM-54GV) The head tilts 45° left or right at the end of the ram.

To tilt the head:

1. DISCONNECT THE MACHINE FROM POWER!
2. Using a spanner, loosen anticlockwise the 3 hexagon nuts located at the rear of head end of the overarm as shown in Fig.5.5

WARNING

Please note that these 3 nuts must only be loosened one quarter to one half (1/4-1/2) of a turn maximum to avoid possibility of the head disengaging from its tilting mechanism and so dropping under its own weight.

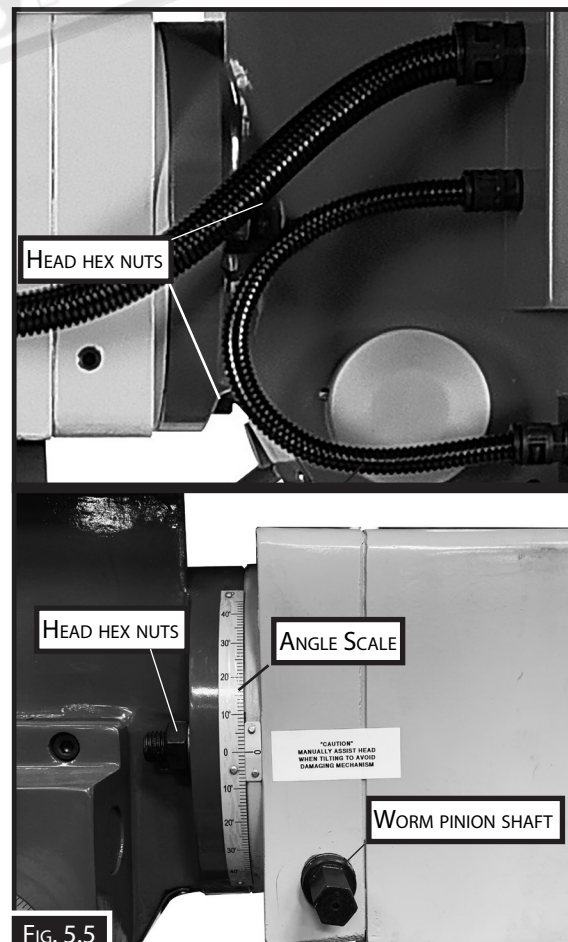

Fig. 5.5

3. It then will be possible to tilt the head down to the required position, by slowly turning the hexagon worm pinion shaft on the right hand side behind the spindle, (Fig.5.6) either clock wise or anticlockwise.
4. When the correct angle of the head is obtained ensure the 3 x hexagon nuts located at the head end of the over arm are firmly re-tightened.

Note: Use the angle scale shown in Fig. 5.5 as a guide for setting tilt angle. For an accurate angle the use of a protractor will be required.

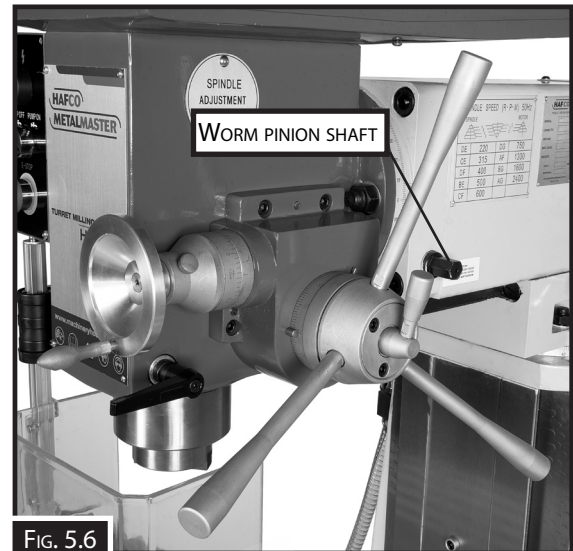

FIG. 5.6

NOTE: Because of the Mill heads heavy overhung weight. It is strongly recommended that when returning the mill head of the machine back up to any position. That, while the hexagon worm pinion shaft on the right hand side of the over arm is turned. A second person should give assistance to push the head back up as needed. Always ensure the 3 x hexagon nuts located at the head end of the over arm are firmly re-tightened after every move.

RAM MOVEMENT

The ram travels forward/backward 300mm and rotates 180° on the turret.

Moving Ram Forward/Backward

1. DISCONNECT THE MACHINE FROM POWER!
2. Loosen the two lock handles shown in Fig.5.7
3. Rotate pinion gear bolt to move ram until spindle is in desired position.
4. Retighten lock handles to secure ram movement before resuming operation.

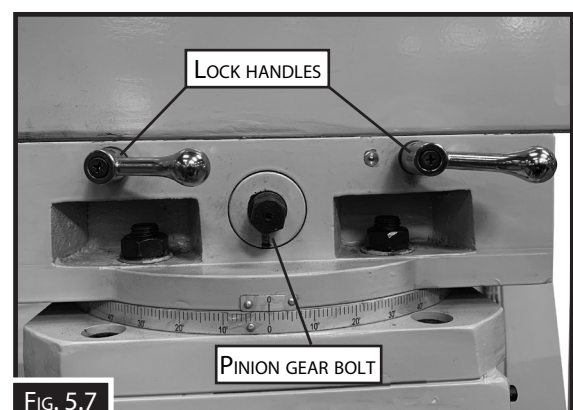

FIG. 5.7

ROTATING RAM ON TURRET

1. DISCONNECT THE MACHINE FROM POWER!
2. Loosen the four hex nuts (two on each side of the ram) that secure ram to turret (Fig. 5.8).
3. Make sure that cables and hoses are not entangled or stretched as you move ram on turret.
4. Retighten the four hex nuts that secure the ram on turret before resuming operation

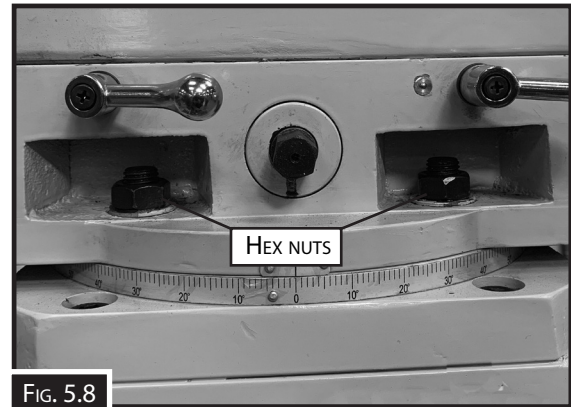

FIG. 5.8

5.3 MOUNTING THE TOOLING

The tooling is held in the spindles by a combination of the a NT-30 taper, inside the spindle, and secured with a M12 drawbar. (Fig. 5.9)

To mount the tooling :

1. DISCONNECT THE MACHINE FROM POWER!
2. Clean any debris or dirt off the matching surfaces from inside spindle taper and mating surface of the tooling.

Note: Debris or oily substances can prevent tooling and the spindle from properly mating. This condition can cause excessive vibration, poor cutting results, or tool/workpiece damage.

3. Hold the tooling inside the spindle and screw the drawbar into the end of the tooling. Make sure that the drawbar screws in at least 16mm before it tightens up in the spindle.
4. Tighten drawbar until it is snug. Avoid overtightening, as this could damage the thread on the drawbar.

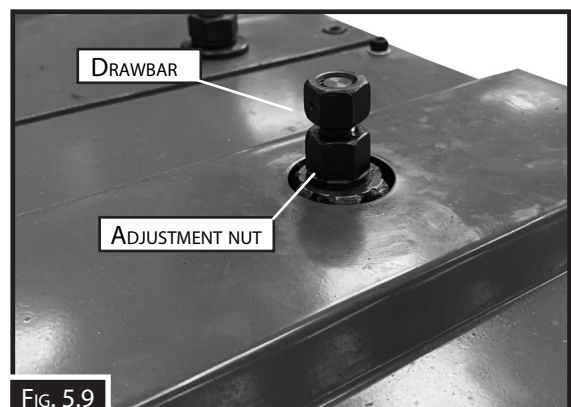

FIG. 5.9

5.4 HORIZONTAL SETUP (HM-54GV)

The horizontal spindle on the model HM-54GV can be used for single or multiple cutters (gang milling). They can be arranged anywhere along the length of the arbor for simple to very complex cutting operations.

To setup for horizontal use:

1. DISCONNECT THE MACHINE FROM THE POWER!
2. Rotate ram 180° until horizontal arbor support is in-line with horizontal spindle (Fig. 5.10).

Note: Make sure the "0" marks on the ram base and angle scale are aligned and the four ram rotation hex nuts are retightened.

3. Extend the ram until horizontal arbor is all the way forward.
4. Loosen locking bolt on side of arbor support, and slide support off ram dovetail way.
5. Clean any debris or surface substances from inside spindle taper and mating surface of the arbor.
6. With one hand holding arbor in place, insert horizontal drawbar into spindle from rear of column, then thread it into arbor.
8. Tighten drawbar until it is snug. Avoid overtightening as this could damage the thread on the drawbar.
9. After the cutters have been placed on the arbor, then slide the arbor support onto the dovetails on the ram and line up the support bush on the arbor.



FIG. 5.10



FIG. 5.11

5.5 CHANGING THE SPINDLE SPEED

It is important for the correct spindle speed to be set to optimize the best performance, as well as maximizing tool life.

When setting the spindle speed for the operation, two things need to be observed:

- (1) Determine the best spindle speed for the cutting task,
- (2) Configure the mill controls to match the closest spindle speed

Determining Spindle Speed

The two most important variables recommended for considering the cutting speed are the workpiece material and the diameter of the cutting tool, when calculating the speed using the equation in Fig. 5.12.

Cutting speed, typically defined in meters per minute (MPM), is the speed at which the edge of a tool moves across the material surface

$$\text{(RPM)} = \frac{\text{CUTTING SPEED M/MIN} \times 1000}{\text{CUTTER DIAMETER} \times 3.14}$$

FIG. 5.12

Setting The Vertical Spindle Speed (HM-51B)

1. DISCONNECT THE MACHINE FROM POWER!
 2. Remove vertical spindle V-belt covers to gain access to vertical V-belts and pulleys (Fig.5.13)
 3. Loosen center pulley hex nut.(Fig.5.13)
 4. Loosen the two motor mount hex bolts (one on each side of motor). (Fig.5.14)
 5. Use motor handle to pull motor towards the front of machine and release V-belt tension. (Fig.5.14)
 6. Check the Spindle Speed Chart and arrange the V-belts to set the vertical spindle speed (Fig.5.15)
 7. Apply pressure on motor handle toward the back of machine to tension V-belts as you retighten center pulley hex nut and motor mount hex bolts.
- Note:** There is proper V-belt tension when approximately 6-12mm deflection is achieved by applying moderate pressure midway between pulleys.
8. Re-install V-belt covers before connecting machine to power



Fig. 5.13

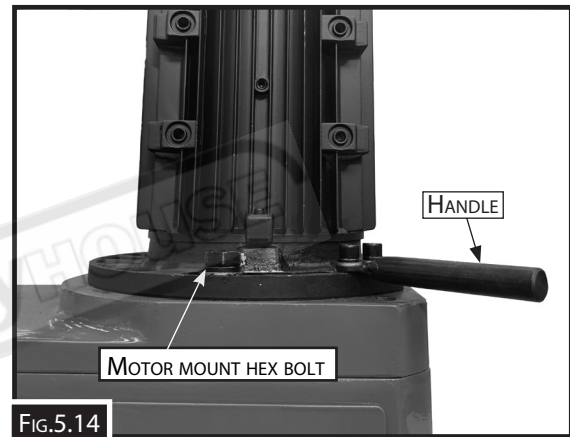

Fig.5.14

SPINDLE SPEED (R.P.M.)			
DE	220	DG	750
CE	315	AF	1300
DF	400	BG	1600
BE	500	AG	2400
CF	600		

FIG. 5.15

NOTE: The variety of shapes and materials machined on milling machines makes it imperative for machine operators to understand the process for selecting suitable cutting tools for each job. Check with an experienced operator, trade websites or trade manuals for advice and information before proceeding with the operation.

Setting The Vertical Spindle Speed (HM-54GV)

The Model HM-54GV is fitted with a variable speed motor and a HIGH or LOW speed gearbox. The speed is controlled by a speed selector knob mounted on the control panel (Fig.5.16) with the HIGH or LOW selected by the lever on the side of the head. (Fig.5.17)
The speed is displayed in R.P.M. on the digital display on the control panel.



FIG.5.16

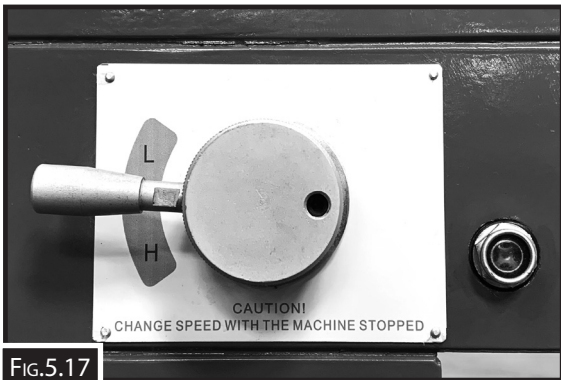

FIG.5.17

Setting The Horizontal Spindle Speed (HM-54GV)

1. DISCONNECT THE MACHINE FROM POWER!
2. Open horizontal V-belt cover to gain access to the horizontal spindle V-belts and pulleys, (Fig. 5.19)
3. Select the speed required from the table below (Fig.5.18)

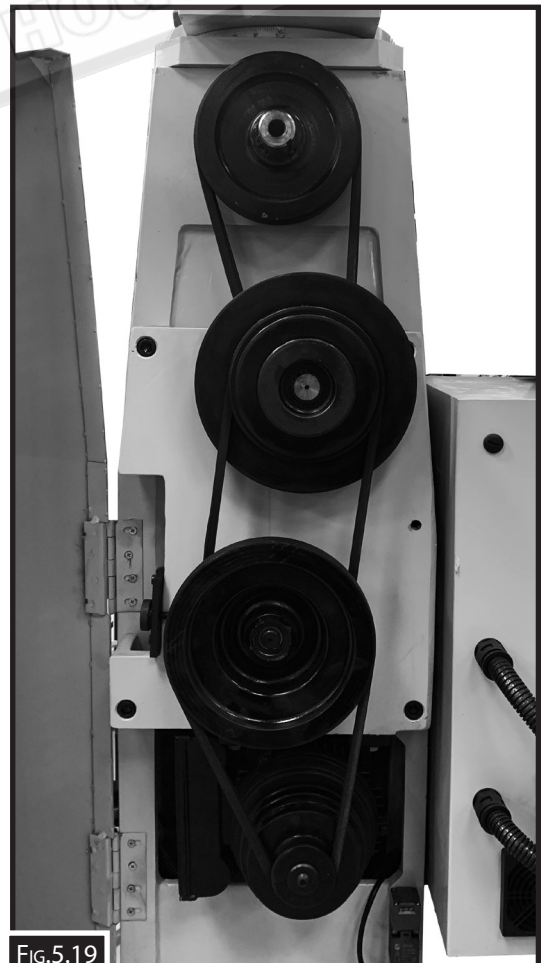

FIG.5.19

HORIZONTAL SPINDLE SPEED (R·P·M)		
1	AG	60
2	BG	140
3	CG	175
4	AF	200
5	AE	240
6	BF	460
7	CE	690
8	BD	1100
9	CD	1350

UPPER

MIDDLE

MOTOR

FIG.5.18

Setting The Horizontal Spindle Speed (HM-54GV) Cont.

4. Loosen tension thumbwheel and hex nut behind lower idler pulley bracket. (Fig.5.20)
4. Move lower idler pulley to the right to release V-belt tension
5. Arrange V-belts for the desired horizontal spindle speed.

NOTE: The horizontal spindle speed chart (Fig.5.18) is also on side of the ram. Apply pressure on lower idler pulley to the left as you tighten tension thumbwheel. (Fig.5.20) The V-belt tension is correct when approximately 6-12mm deflection is achieved by applying moderate pressure midway between pulleys.

7. Retighten hex nut behind lower idler pulley bracket. (Fig.5.20)
8. Close and latch

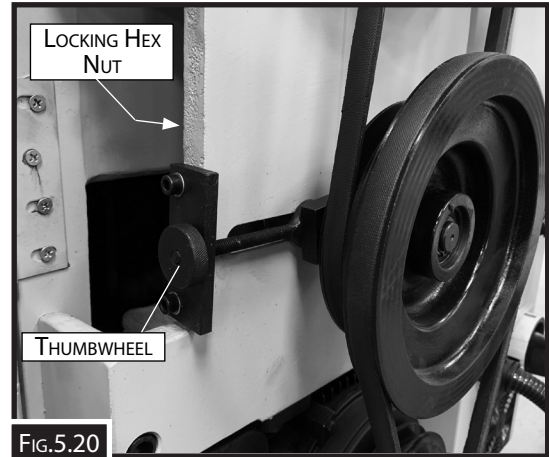

FIG.5.20

Spindle Downfeed Controls

Listed below are the descriptions and explanations to help understand the downfeed components that control the spindle downfeed travel. (Fig.5.21)

- A. Fine Downfeed Handwheel:** Manually controls the slow downfeed travel. The attached graduated dial has increments of 0.05mm with one full revolution representing 2.5mm of travel.
- B. Selection Lever:** When tightened, enables the fine downfeed handwheel; conversely, when loosened enables the coarse downfeed levers
- C. Coarse Downfeed Levers:** Manually control rapid downfeed travel.
- D. Quill Lock:** Secures the quill in place for increased stability during operations.

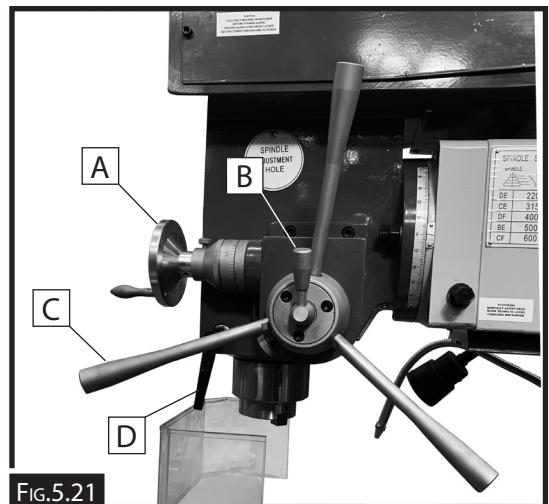

FIG.5.21

6. MAINTENANCE

The mills in this manual have numerous moving metal-to-metal points that require regular and proper lubrication to ensure efficient and long-lasting operation.

Other than the lubrication points covered in this section, all other bearings are internally lubricated and sealed at the factory. These will not require attention unless they need to be replaced.

Before performing any lubrication task! **DISCONNECT THE MACHINE FROM POWER**

Before adding lubricant, make sure that the lubricating points are clean of dirt and grime.

6.1 LUBRICATION SCHEDULE

Lubrication Points	Frequency	Lubricant
Ball Oilers	Daily	ISO 32 Equivalent
Vertical Spindle Bearings	Daily	ISO 32 Equivalent
Quill Exterior	Daily	ISO 68 Equivalent
Quill Rack & Pinion	Weekly	ISO 68 Equivalent
Table Leadscrews	Weekly	ISO 68 Equivalent
Ram Ways	Weekly	ISO 68 Equivalent
Z-Axis Bevel Gears	Monthly	NLGI#2 Grease
X-Axis Power Feed Gears	Monthly	NLGI#2 Grease

Ball Oilers

Ball oilers are found on each slide, lead screw spindles and the ram. (Sample see Fig.6.1)
 Push the tip of the oil can nozzle against the ball oiler to create a hydraulic seal, then pump the oil can once or twice. If you see sludge and dirty oil coming out of the lubrication area, continue pumping the oil can until the oil runs clear. When finished, wipe away the excess oil.

NOTE: Make sure that the oiler has been cleaned and is free of dirt before lubricating.

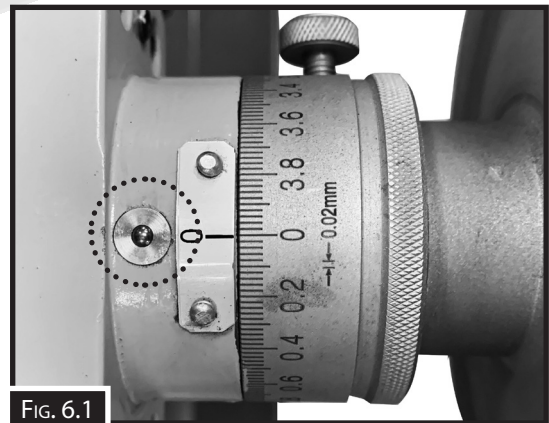

FIG. 6.1

Gearbox (HM-54GV)

The model HM-54GV is a geared head mill and the gearbox needs to be checked that the oil level in the gearbox is kept at the correct level.

A site glass on the head should display an oil level up to the halfway mark in the site glass. (Fig.6.2)



FIG. 6.2

6.2 GIB ADJUSTMENT

Gibs are tapered lengths of metal that are sandwiched between two moving surfaces. Gibs control the gap between these surfaces and how they slide past one another. Correctly adjusting the gibs is critical to producing good milling results.

Tight gibs make table movement more accurate but stiff. Loose gibs make moving the table sloppy but easier to do. The goal of gib adjustment is to remove unnecessary sloppiness without causing the ways to bind.

Gibs are adjusted with a screw on each end of the gib, that move the tapered gib back-and-forth to increase or decrease the friction pressure between the sliding surfaces. The process of properly adjusting the gibs requires trial-and-error and patience.

Refer to Fig. 6.3-6.5 to identify the locations of the table, saddle, and knee gibs, and one of the two adjustment screws for each.

NOTE: It will be necessary to remove small parts, such as way wipers and covers, to access the gib adjustment screws.

The following is the method used to adjust the gibs.

1. DISCONNECT MACHINE FROM POWER!
2. Make sure all table/knee locks are loose.
3. Loosen one gib adjustment screw, then `` tighten the other the same amount to move the gib.
4. Use the handles/crank to move table/knee until you feel a slight drag in the path of movement. Repeat Steps 3–4 as necessary.



FIG. 6.3



FIG. 6.4

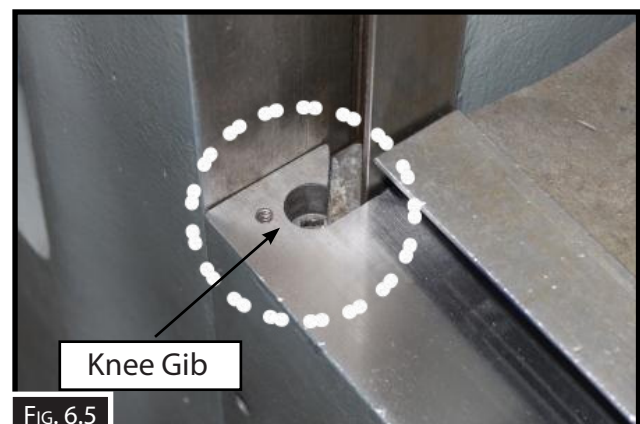

FIG. 6.5

Fig. 31 Knee Gib Adjustment

OPERATION MANUAL

6.3 TROUBLESHOOTING

Read the troubleshooting section if a problem develops with your machine. If you need any assistance or additional help with a problem, call the Service Department. For spare parts go to www.machineryhouse.com.au/contactus and fill out the enquiry form attaching a copy of a scanned parts list.

Symptom	Possible Cause	Possible Solution
Machine does not start or a breaker trips.	<ol style="list-style-type: none"> 1. Plug/receptacle at fault/wired wrong. 2. Incorrect power supply voltage/circuit size. 3. Power supply circuit breaker tripped or fuse blown. 4. Motor wires connected incorrectly. 5. Wiring open/has high resistance. 6. Spindle rotation switch at fault. 7. Start capacitor at fault . 8. Centrifugal switch at fault . 9. Motor at fault. 	<ol style="list-style-type: none"> 1. Test for good contacts; correct the wiring. 2. Ensure correct power supply voltage/circuit size. 3. Ensure circuit is sized correctly and free of shorts. Reset circuit breaker or replace fuse. 4. Correct motor wiring connections. 5. Check/fix broken, disconnected, or corroded wires. 6. Replace switch. 7. Test/replace. 8. Adjust/replace centrifugal switch if available. 9. Test/repair/replace.
Machine stalls or is underpowered	<ol style="list-style-type: none"> 1. Machine undersized for task. 2. Feed rate/cutting speed too fast. 3. Wrong workpiece material. 4. Belt(s) slipping. 5. Oil/grease on belt(s). 6. Motor wired incorrectly. 7. Spindle rotation switch at fault. 8. Gearbox at fault. 9. Motor overheated. 10. Pulley/sprocket slipping on shaft. 11. Centrifugal switch at fault. 12. Motor bearings at fault. 	<ol style="list-style-type: none"> 1. Use correct cutter/bit; reduce feed rate; reduce spindle RPM; use coolant if possible. 2. Decrease feed rate/cutting speed. 3. Use correct type/size of metal. 4. Tension/replace belt(s); ensure pulleys are aligned. 5. Clean belt(s). 6. Wire motor correctly. 7. Test/replace switch. 8. Select appropriate gear ratio; replace broken or slipping gears. 9. Clean motor, let cool, and reduce workload. 10. Replace loose pulley/shaft. 11. Adjust/replace centrifugal switch if available. 12. Test/repair/replace.
Machine has vibration or noisy operation.	<ol style="list-style-type: none"> 1. Workpiece loose. 2. Belt(s) worn or loose. 3. Motor or component loose. 4. Chuck or cutter at fault. 5. Belt(s) slapping headstock casting/guard. 6. Motor fan rubbing on fan cover. 7. Pulley loose. 8. Machine incorrectly mounted. 9. Motor bearings at fault. 10. Centrifugal switch is at fault . 	<ol style="list-style-type: none"> 1. Use the correct holding fixture/reclamp workpiece. 2. Inspect/replace belts with a new matched set. 3. Inspect/replace damaged bolts/nuts, and retighten with thread locking fluid. 4. Replace unbalanced chuck; replace/resharpen cutter; use correct feed rate. 5. Replace/realign belts with a matched set. 6. Fix/replace fan cover; replace loose/damaged fan. 7. Re-align/replace shaft, pulley set screw, and key. 8. Tighten mounting bolts; relocate/shim machine. 9. Test by rotating shaft; rotational grinding/loose shaft requires bearing replacement. 10. Replace

OPERATION MANUAL

TROUBLESHOOTING

Symptom	Possible Cause	Possible Solution
Tool loose in spindle.	<ol style="list-style-type: none"> 1. Tool is not fully drawn up into spindle taper. 2. Debris on tool or in spindle taper 3. Taking too big of a cut. 	<ol style="list-style-type: none"> 1. Tighten drawbar. 2. Clean tool and spindle taper. 3. Lessen depth of cut and allow chips to clear.
Breaking tools or cutters.	<ol style="list-style-type: none"> 1. Spindle speed/feed rate is too fast. 2. Cutting tool is too small. 3. Cutting tool getting too hot. 4. Taking too big of a cut. 5. Spindle extended too far down. 	<ol style="list-style-type: none"> 1. Set spindle speed correctly or use slower feed rate 2. Use larger cutting tool and slower feed rate. 3. Use coolant or oil for appropriate application. 4. Lessen depth of cut and allow chips to clear. 5. Fully retract spindle and raise table. This increases rigidity.
Workpiece or tool vibrates or chatters during operation.	<ol style="list-style-type: none"> 1. Table locks not tight. 2. Workpiece not secure. 3. Spindle speed/feed rate is too fast. 4. Spindle extended too far down 5. Quill lock lever not tight. 6. Gibs too loose in table. 	<ol style="list-style-type: none"> 1. Tighten table locks (Page 10). 2. Properly clamp workpiece on table or in vise. 3. Set spindle speed correctly or use slower feed rate (Page 15,16). 4. Fully retract spindle and raise table This increases rigidity. 5. Tighten quill lock lever (Page 8.9). 6. Tighten gibs (Page 26).
Table is hard to move.	<ol style="list-style-type: none"> 1. Table locks are tightened down. 2. Chips have loaded up on ways. 3. Ways are dry and need lubrication. 4. Table limit stops are interfering. 5. Gibs are too tight. 	<ol style="list-style-type: none"> 1. Fully release table locks (Page 10). 2. Frequently clean away chips or debris. 3. Lubricate ways (Page 25). 4. Make sure that table limit stops are not in the way 5. Adjust gibs (Page 26).
Headstock is hard to raise.	<ol style="list-style-type: none"> 1. Headstock lock(s) or gib is at fault. 2. Headstock leadscrew is binding. 3. Gib is too tight. 	<ol style="list-style-type: none"> 1. Loosen/replace lock lever and adjust gib (2. Clean and relubricate headstock leadscrew and gears 3. Adjust gib (Page 26).
Bad surface finish	<ol style="list-style-type: none"> 1. Spindle speed/feed rate is too fast. 2. Dull or incorrect cutting tool. 3. Wrong rotation of cutting tool 4. Workpiece not secure. 5. Spindle extended too far down. 	<ol style="list-style-type: none"> 1. Set spindle speed correctly or use slower feed rate (Page 16). 2. Sharpen cutting tool or select one that better suits the operation. 3. Check for proper cutting tool rotation. 4. Properly clamp workpiece on table or in vise. 5. Fully retract spindle and raise table. This increases rigidity.
Cutting results not square.	<ol style="list-style-type: none"> 1. Table and spindle are not at 90° to each other. 2. Table travel is inconsistent 	<ol style="list-style-type: none"> 1. Square the spindle (Page 23). 2. Adjust gibs (Page 26).
Spindle overheats.	<ol style="list-style-type: none"> 1. Poor spindle bearing lubrication. 2. Spindle bearings too tight. 3. Mill operated at high speeds for extended period. 	<ol style="list-style-type: none"> 1. Replace spindle bearings. 2. Properly adjust spindle bearing preload. 3. Allow mill to cool.
Lack of power at spindle.	<ol style="list-style-type: none"> 1. Belts are loose. 2. Wrong voltage 	<ol style="list-style-type: none"> 1. Properly tension belts. 2. Correct voltage.

OPERATION MANUAL

TROUBLESHOOTING

Symptom	Possible Cause	Possible Solution
Spindle does not fully retract.	1. Poorly adjusted return spring. 2. Worn return spring.	1. Increase return spring tension. 2. Replace return spring
Spindle switch does not work.	1. Shorted/disconnected wiring.	1. Inspect wiring connections. Replace/repair as necessary.

Power Feed

Powerfeed does not move table or is slipping.	1. Table locked. 2. Drive selector not engaged. 3. Sheared pin. 4. Gears not meshing or teeth missing. 5. Motor shaft and gear shaft not engaged	1. Unlock table locks. 2. Select speed, engage drive selector. 3. Replace pin. 4. Check gears and adjust/replace. 5. Replace clutch.
Operates at high speed only or is inconsistent.	1. Rapid micro switch is stuck. 2. V.R. does not work properly. 3. Wiring harness unplugged from circuit board	1. Lightly tap on it to lower it. 2. Test/repair/replace 3. Reconnect wiring harness.

Digital Readout Unit (DRO)

DRO does not give reading.	1. DRO is not turned on/plugged in. 2. Shorted/disconnected wiring/plugs..	1. Press DRO ON/Power button/plug in. 2. Inspect circuit boards, sensors, plugs, and wiring connections. Replace/repair as necessary.
DRO reading is incorrect.	1. Initial reading is incorrect. 2. Sensor has gone bad. 3. Spacing between sensor & scale is incorrect.	1. Test/zero/reset DRO at beginning point. 2. Test/replace sensor as necessary. 3. Adjust spacing between sensor and scale

Lamp

Lamp will not light.	1. Power not turned on. 2. Bulb is burned out. 3. Short in wiring or wired incorrectly	1. Press switch/button on lamp or control panel. 2. Replace bulb. 3. Trace and test wiring. Fix any errors.
----------------------	--	---

SPARE PARTS SECTION

The following section covers the spare parts diagrams and lists that were current at the time this manual was originally printed. Due to continuous improvements of the machine, changes may be made at any time without notification.

HOW TO ORDER SPARE PARTS

1. Have your machines model number, serial number & date of manufacture on hand, these can be found on the specification plate mounted on the machine
2. A scanned copy of your parts list/diagram with required spare part/s identified
3. Go to www.machineryhouse.com.au/contactus and fill out the enquiry form attaching a copy of scanned parts list.



OPERATION MANUAL

A: COLUMN PARTS HM-51B

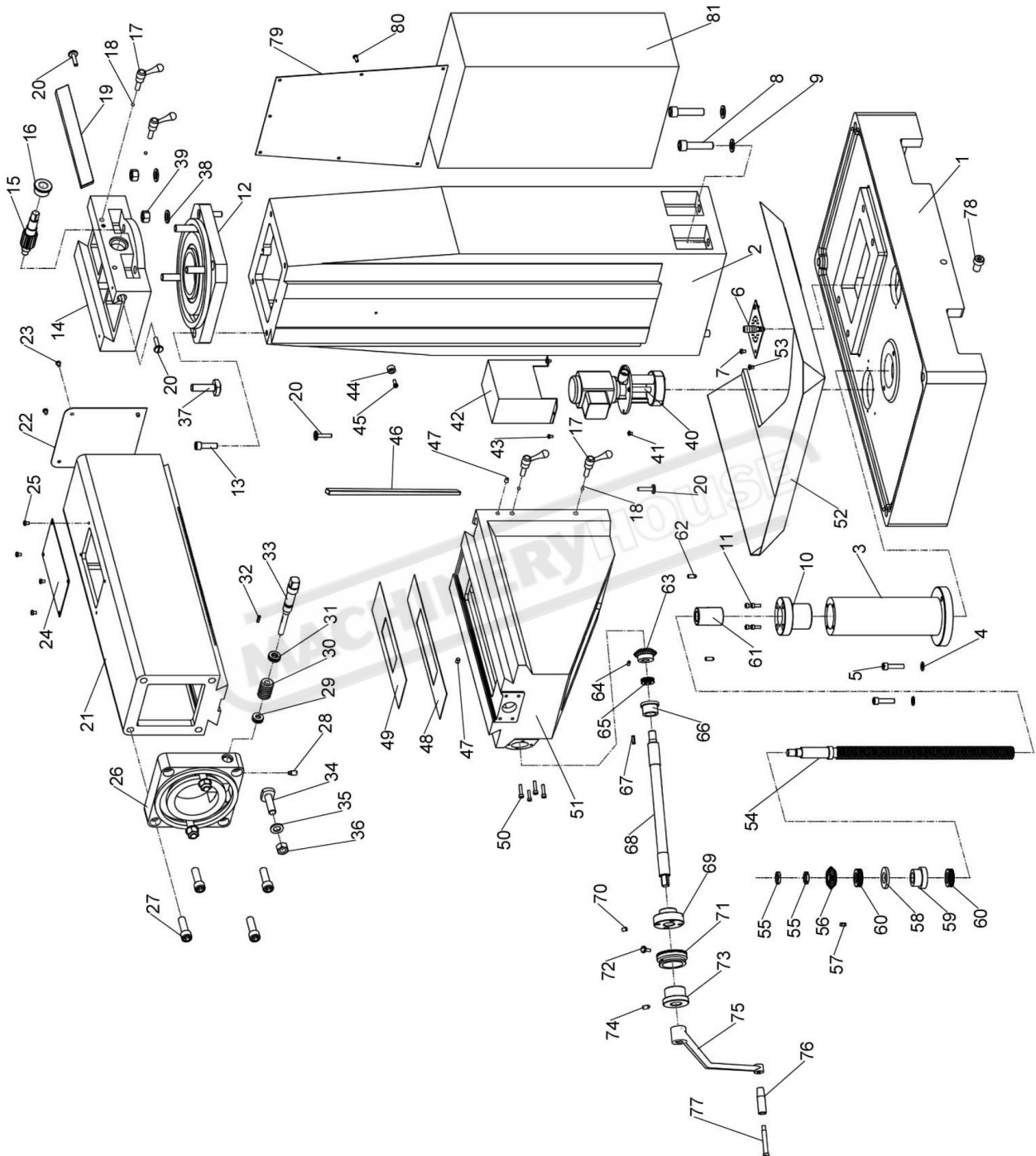



OPERATION MANUAL

A: COLUMN PARTS LIST HM-51B

No.	Description	Qty.	No.	Description	Qty.
1	BASE	1	45	SCREW M6x18	1
2	COLUMN	1	46	GIB	1
3	ELEVATING SCREW HOUSING	1	47	BILLIARD OIL CUP	4
4	LOCK WASHER 10MM	2	48	WIPER PLATE	1
5	HEX BOLT M10-1.5x45	2	49	WIPER PLATE	1
6	CONNECT TUBE	1	50	CAP SCREW M6X25	4
7	PHLP HD SCR M6x12	4	51	KNEE	1
8	HEX BOLT M16-2x65	4	52	OIL PAN	1
9	LOCK WASHER 16MM	4	53	CAP SCREW M6X12	2
10	COLLAR	1	54	HOIST DESCEND LEAD SCREW	1
11	CAP SCREW M8-1.25x25	2	55	CIRCULAR NUT M16X1.5	2
12	HOLD SUPPORT	1	56	CONICAL GEAR	1
13	CAP SCREW M12-1.75x30	4	57	KEY 6x6x12	1
14	AROUND BRACKET	1	58	ADJUST WASHER	1
15	FEED SHAFT	1	59	COLLAR	1
16	COLLAR	1	60	BALL BEARING 51105	2
17	CLAMP BOLT M10-1.5x53x25	4	61	NUT 42x60MM	1
18	CLAMP BLOCK	4	62	SET SCREW M8X20	2
19	GIB	1	63	CONICAL GEAR	1
20	FLAT HD SCR M8-1.25x40	4	64	SET SCREW M6-1x10	1
21	OVERARM	1	65	BALL BEARING 51103	1
22	COVER	1	66	COLLAR	1
23	PHLP HD SCR M6-.1x10	4	67	KEY 5x5x20	1
24	COVER	1	68	SHAFT	1
25	PHLP HD SCR M6-.1x10	4	69	COLLAR	1
26	HOLD BRACKET	1	70	CAP SCREW M6-1x22	1
27	CAP SCREW M16-2x50	4	71	SCALE RING	1
28	CAP SCREW M8x20	1	72	KNURLED THUMB SCR M6-1x10	1
29	BALL BEARING 51101	1	73	COLLAR	1
30	WORM	1	74	SET SCREW	1
31	BALL BEARING 51102	1	75	HANDLE	1
32	KEY 4x 4x20	1	76	TAPER KNOB	1
33	WORM SHAFT	1	77	HANDLE SPINDLE	1
34	T BOLT M16-2x60	3	78	SCREW	1
35	WASHER 16MM	3	79	BEHIND COVER	1
36	HEX NUT M16-2	3	80	FLAT HD SCR M5x12	4
37	T BOLT M16-2x50	4			
38	WASHER 16mm	4			
39	HEX NUT M16-2	4			
40	ELECTRIC PUMP	1			
41	CAP SCREW M5X12	4			
42	SHIELD	1			
43	CAP SCREW M5X12	2			
44	SLEEVE	1			



OPERATION MANUAL

B: SWIVEL TABLE PARTS HM-51B

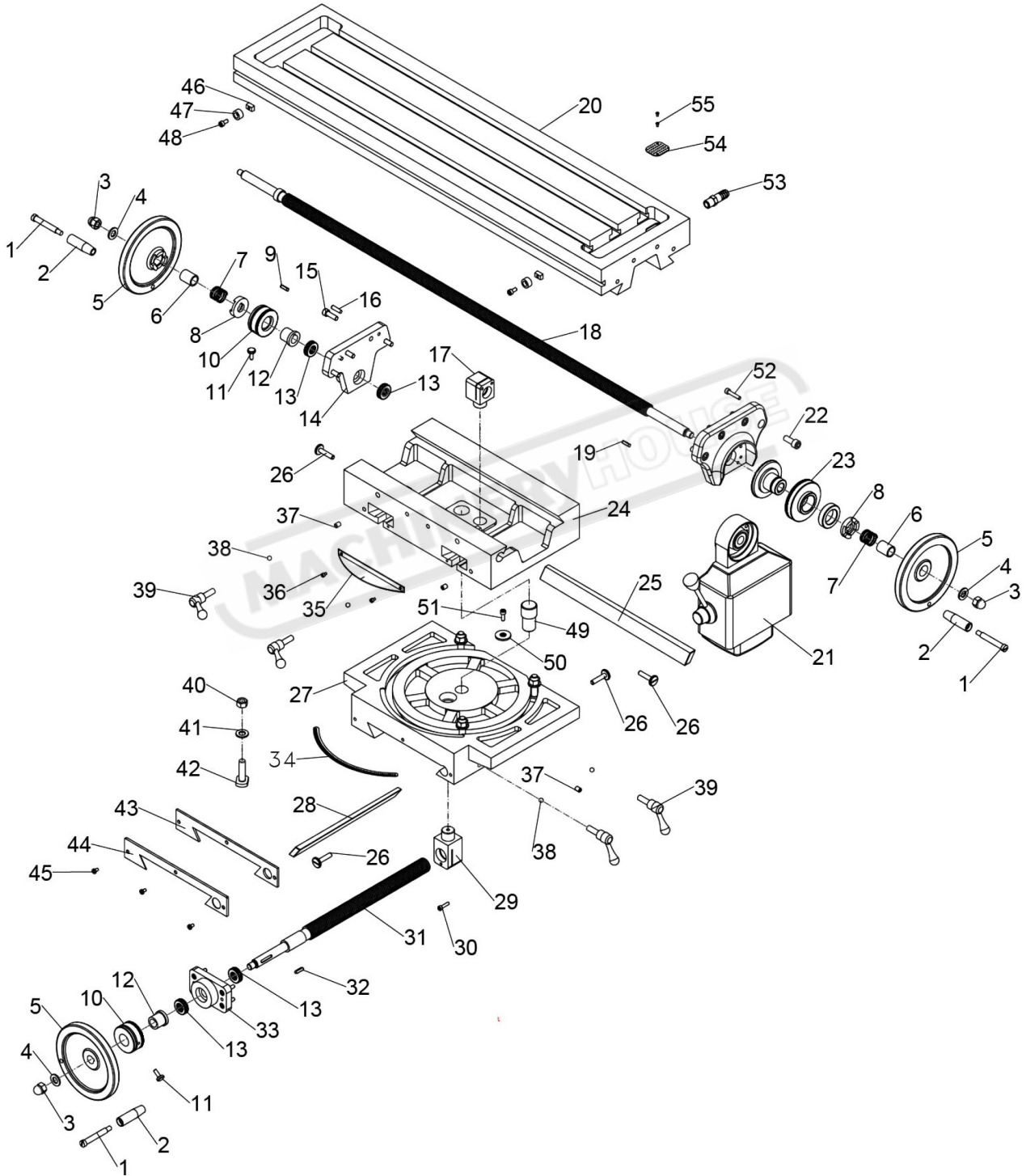

OPERATION MANUAL

B: SWIVEL TABLE PARTS LIST HM-51B

No.	Description	Qty.	No.	Description	Qty.
1	HANDLE SPINDLE	3	29	SPECIAL NUT	1
2	TAPER KNOB	3	30	SCREWM5x25	3
3	HEX NUT M12-1.75	3	31	LONG LEAD SCREW	1
4	LOCK WASHER 12MM	3	32	KEY 5x30	1
5	HAND WHEEL	3	33	SUPPORT	1
6	BUSH	2	34	ANGLE RULER	1
7	SPRING	2	35	GUARD	1
8	CONNECT	2	36	SCREWM5X10	2
9	KEY 5x20mm	1	37	OIL CUP 8	4
10	SCALE RING	2	38	CLAMP BLOCK	4
11	CAP SCREW M6-1x16	2	39	CLAMP BOLT M10-1.5x53x25	4
12	COLLAR	2	40	HEX NUT M12	4
13	BALL BEARING 51103	4	41	WASHER 12	4
14	SUPPORT	1	42	T BOLT M12X1.75X42	4
15	CAP SCREW M8x25	6	43	WIPER PLATE	1
16	PIN 6x25mm	2	44	WAY COVER	1
17	SPECIAL NUT	1	45	PHLP HD SCR M5-.8x12	3
18	LONG LEAD SCREW	1	46	SCREW BRACKET	1
19	KEY 5X20mm	1	47	DOG	1
20	TABLE	1	48	CAP SCREW M6-1x16	1
21	POWER FEED	1	49	SHAFT	1
22	CAP SCREW M10x25mm	4	50	WASHER	1
23	SCALE RING	1	51	SCREWM6X30	1
24	ROTARY BRACKET	1	52	PIN 6x25	2
25	GIB	1	53	CONNECT TUBE	1
26	ADJUST SCREW M8-1.25mm	3	54	SPLASH GUARD	1
27	CENTER BASE	1	55	SCREWM4X8	2
28	GIB	1			



OPERATION MANUAL

C: VERTICAL BELT SPINDLE PARTS HM-51B

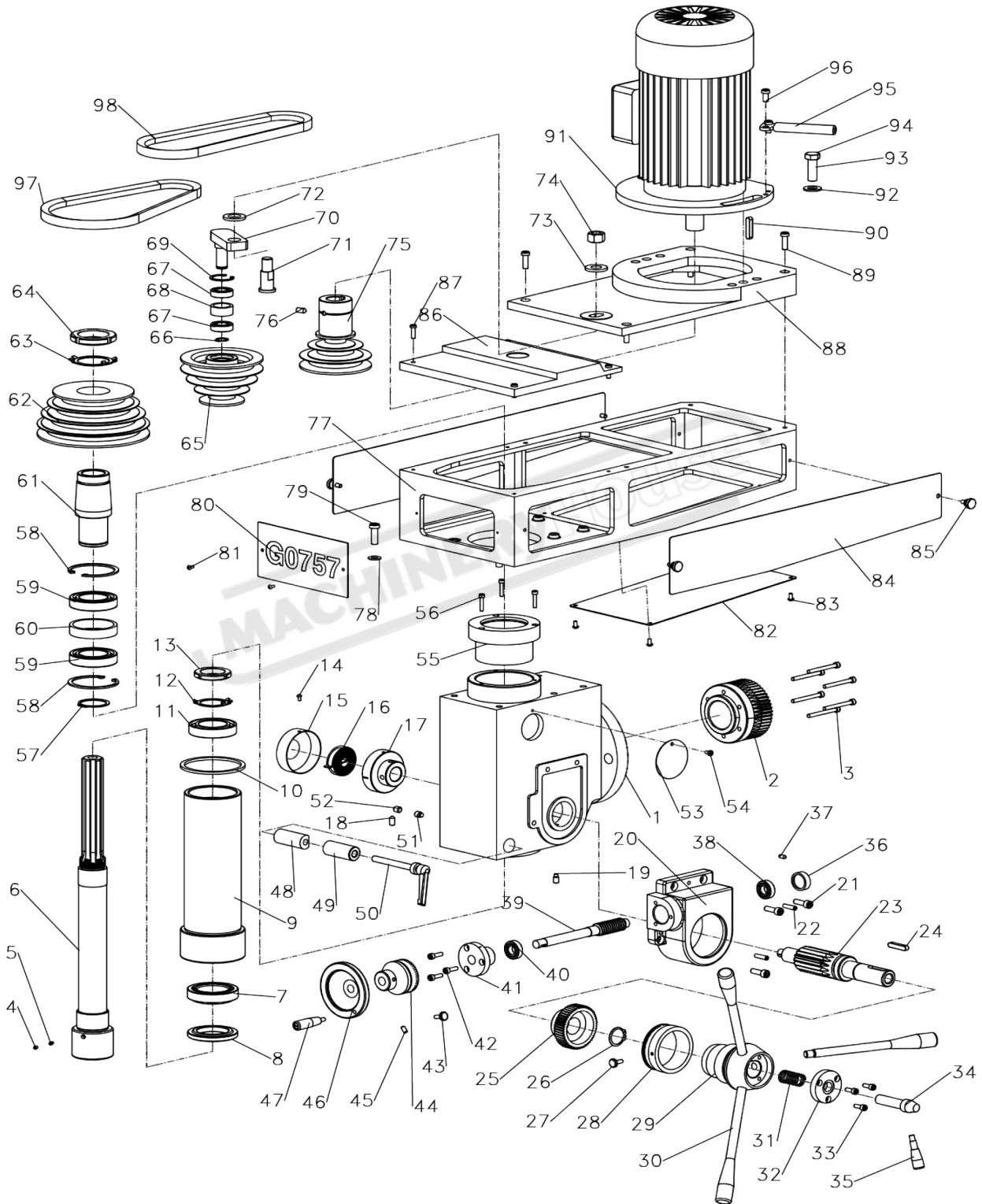



OPERATION MANUAL

C: VERTICAL BELT SPINDLE PARTS LIST HM-51B

No.	Description	Qty.	No.	Description	Qty.
1	SPINDLE BOX	1	50	CLAMP HANDLE	1
2	GEAR	1	51	SET SCREW M10X10	1
3	BOLT	6	52	SET SCREW M10X10	1
4	SCREWM5X6	1	53	BAFFLE	1
5	SCREWM5X6	1	54	SCREWM5X10	1
6	SPINDLE	1	55	COLLAR	1
7	BALL BEARING 32010/P5	1	56	SCREWM5X30	3
8	WASHER	1	57	EXT RETAINING RING 45	1
9	SLEEVE	1	58	INT RETAINING RING75	2
10	RUBBER WASHER	1	59	BALL BEARING 6009/P5	2
11	BALL BEARING 6009/P5	1	60	RING	1
12	LOCK WASHER 40	1	61	DRIVING SHAFT	1
13	LOCK NUT M40X1.5	1	62	PULLEY	1
14	CAP SCREW M4X8	1	63	LOCK WASHER 50	1
15	SPRING CAP	1	64	LOCK NUT M50X1.5	1
16	SPRING PLATE	1	65	PULLEY	1
17	SPRING BASE	1	66	EXT RETAINING RING 17	1
18	SET SCREW M8X16	1	67	BALL BEARING 6003	2
19	SET SCREW M8X16	1	68	BUSHING	1
20	HANDL WHEEL GEAR BOX	1	69	INT RETAINING RING 35	1
21	SCREWM8X25	3	70	CENTER PULLEY SHAFT	1
22	PIN 6X25	2	71	SMALL SHAFT	1
23	FEED SHAFT	1	72	WASHER	1
24	KEY 8X38	1	73	WASHER	1
25	HELICAL GEAR	1	74	HEX NUT M16	1
26	EXT RETAINING RING 30	1	75	MOTOR PULLEY	1
27	CAP SCREW M6X16	1	76	SET SCREW M8X12	1
28	SCALE RING	1	77	MOTOR BASE	1
29	HANDLE BRACKET HUB	1	78	WASHER 10	6
30	HANDLE BAR	3	79	SET SCREW M10X30	6
31	COMPRESSION SPRING	1	80	SCUTCHEON	1
32	COVER	1	81	RIVET	2
33	SCREWM6X12	3	82	COVER	1
34	HANDLE	1	83	SCREWM5X10	4
35	HANDLE BAR	1	84	COVER	2
36	COVER	1	85	SCREW	4
37	SCREWM6X12	1	86	COVER	1
38	BALL BEARING 6002	1	87	SCREWM6X16	4
39	WORM	1	88	HEAD BOX COVER	1
40	BALL BEARING 6002	1	89	SCREWM8X30	4
41	COVER	1	90	KEY 8X40	1
42	SCREWM6X20	3	91	MOTOR	1
43	LOCK SCREW M6X16	1	92	WASHER 14	2
44	SCALE RING	1	93	BOLT M14X40	2
45	SET SCREW M6X12	1	94	HEX NUT M14	2
46	HANDLE WHEEL	1	95	HANDLE	1
47	HANDLE	1	96	SCREWM8X25	1
48	CLAMP BLOCK	1	97	V-BELT B737	1
49	CLAMP BLOCK	1	98	V-BELT B737	1

D: ELECTRICAL DIAGRAM HM-51B

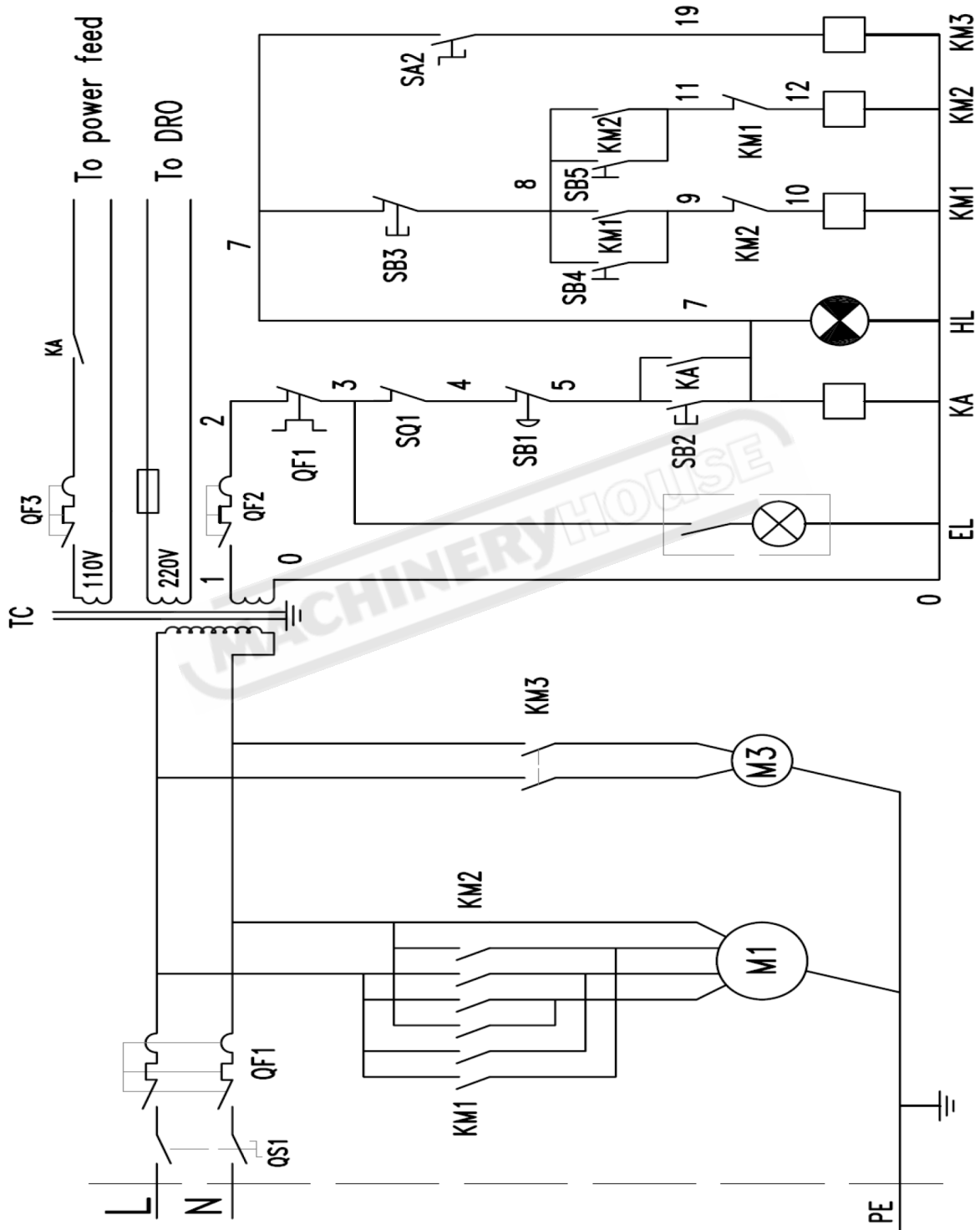



OPERATION MANUAL

A: COLUMN PARTS HM-54GV

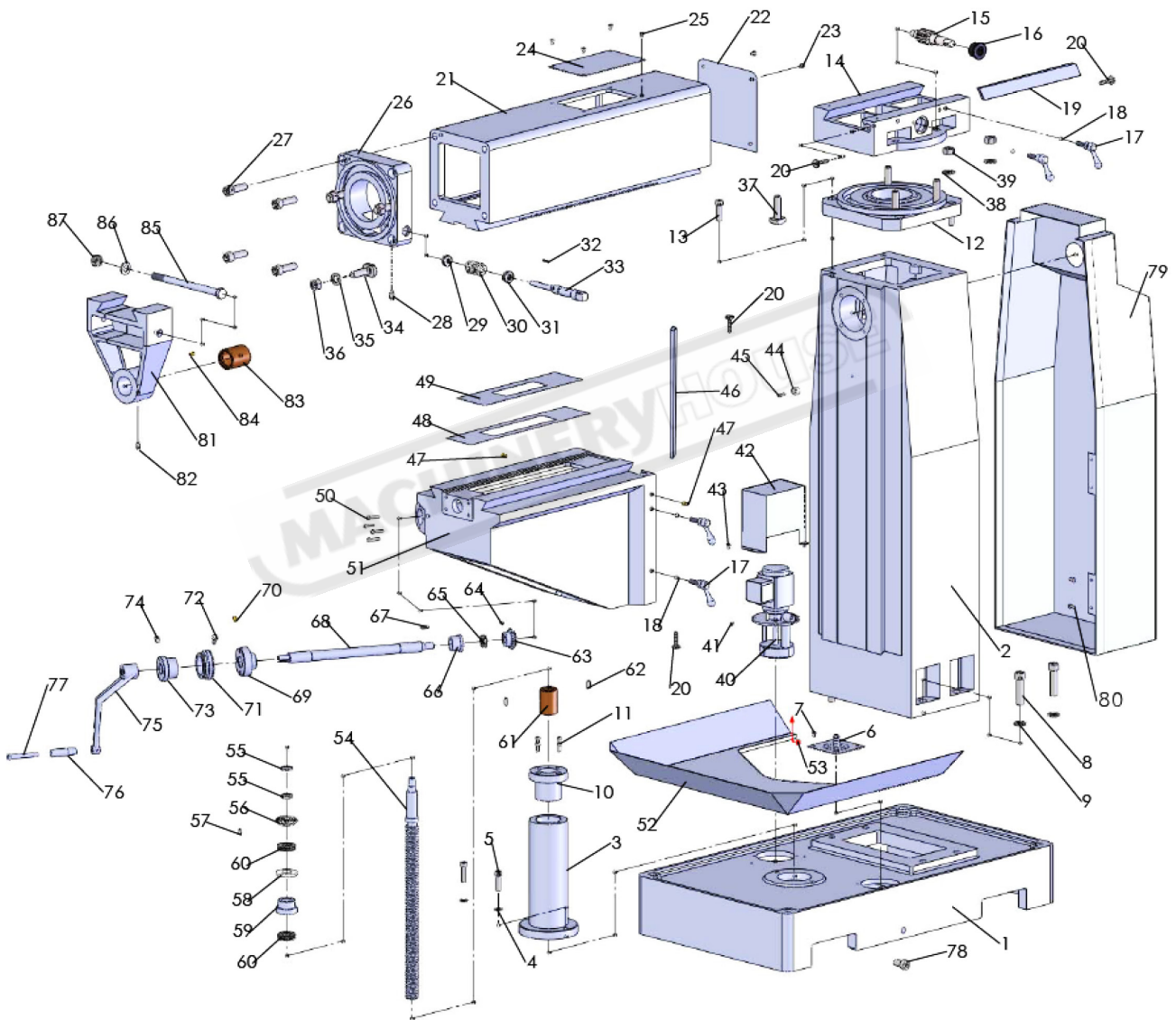

OPERATION MANUAL

A: COLUMN PARTS LIST HM-54GV

No.	Description	Qty.	No.	Description	Qty.
1	BASE	1	45	SCREW M6x18	1
2	COLUMN	1	46	GIB	1
3	ELEVATING SCREW HOUSING	1	47	BILLIARD OIL CUP	4
4	LOCK WASHER 10MM	2	48	WIPER PLATE	1
5	HEX BOLT M10-1.5x45	2	49	WIPER PLATE	1
6	CONNECT TUBE	1	50	CAP SCREW M6X25	4
7	PHLP HD SCR M6x12	4	51	KNEE	1
8	HEX BOLT M16-2x65	4	52	OIL PAN	1
9	LOCK WASHER 16MM	4	53	CAP SCREW M6X12	2
10	COLLAR	1	54	HOIST DESCEND LEAD SCREW	1
11	CAP SCREW M8-1.25x25	2	55	CIRCULAR NUT M16X1.5	2
12	HOLD SUPPORT	1	56	CONICAL GEAR	1
13	CAP SCREW M12-1.75x30	4	57	KEY 6x6x12	1
14	AROUND BRACKET	1	58	ADJUST WASHER	1
15	FEED SHAFT	1	59	COLLAR	1
16	COLLAR	1	60	BALL BEARING 51105	2
17	CLAMP BOLT M10-1.5x53x25	4	61	NUT 42x60MM	1
18	CLAMP BLOCK	4	62	SET SCREW M8X20	2
19	GIB	1	63	CONICAL GEAR	1
20	FLAT HD SCR M8-1.25x40	4	64	SET SCREW M6-1x10	1
21	OVERARM	1	65	BALL BEARING 51103	1
22	COVER	1	66	COLLAR	1
23	PHLP HD SCR M6-.1x10	4	67	KEY 5x5x20	1
24	COVER	1	68	SHAFT	1
25	PHLP HD SCR M6-.1x10	4	69	COLLAR	1
26	HOLD BRACKET	1	70	CAP SCREW M6-1x22	1
27	CAP SCREW M16-2x50	4	71	SCALE RING	1
28	CAP SCREW M8x20	1	72	KNURLED THUMB SCR M6-1x10	1
29	BALL BEARING 51101	1	73	COLLAR	1
30	WORM	1	74	SET SCREW	1
31	BALL BEARING 51102	1	75	HANDLE	1
32	KEY 4x 4x20	1	76	TAPER KNOB	1
33	WORM SHAFT	1	77	HANDLE SPINDLE	1
34	T BOLT M16-2x60	3	78	SCREW	1
35	WASHER 16MM	3	79	BEHIND COVER	1
36	HEX NUT M16-2	3	80	FLAT HD SCR M5x12	4
37	T BOLT M16-2x50	4	81	SUPPORT	1
38	WASHER 16mm	4	82	SET SCREW M8-1.25x16	1
39	HEX NUT M16-2	4	83	SLEEVE	1
40	ELECTRIC PUMP	1	84	BILLIARD OIL CUP	1
41	CAP SCREW M5X12	4	85	SPECIAL BOLT M16-2x218	1
42	SHIELD	1	86	FLAT WASHER 16MM	1
43	CAP SCREW M5X12	2	87	HEX NUT M16-2	1
44	SLEEVE	1			



OPERATION MANUAL

B: SWIVEL TABLE PARTS HM-54GV

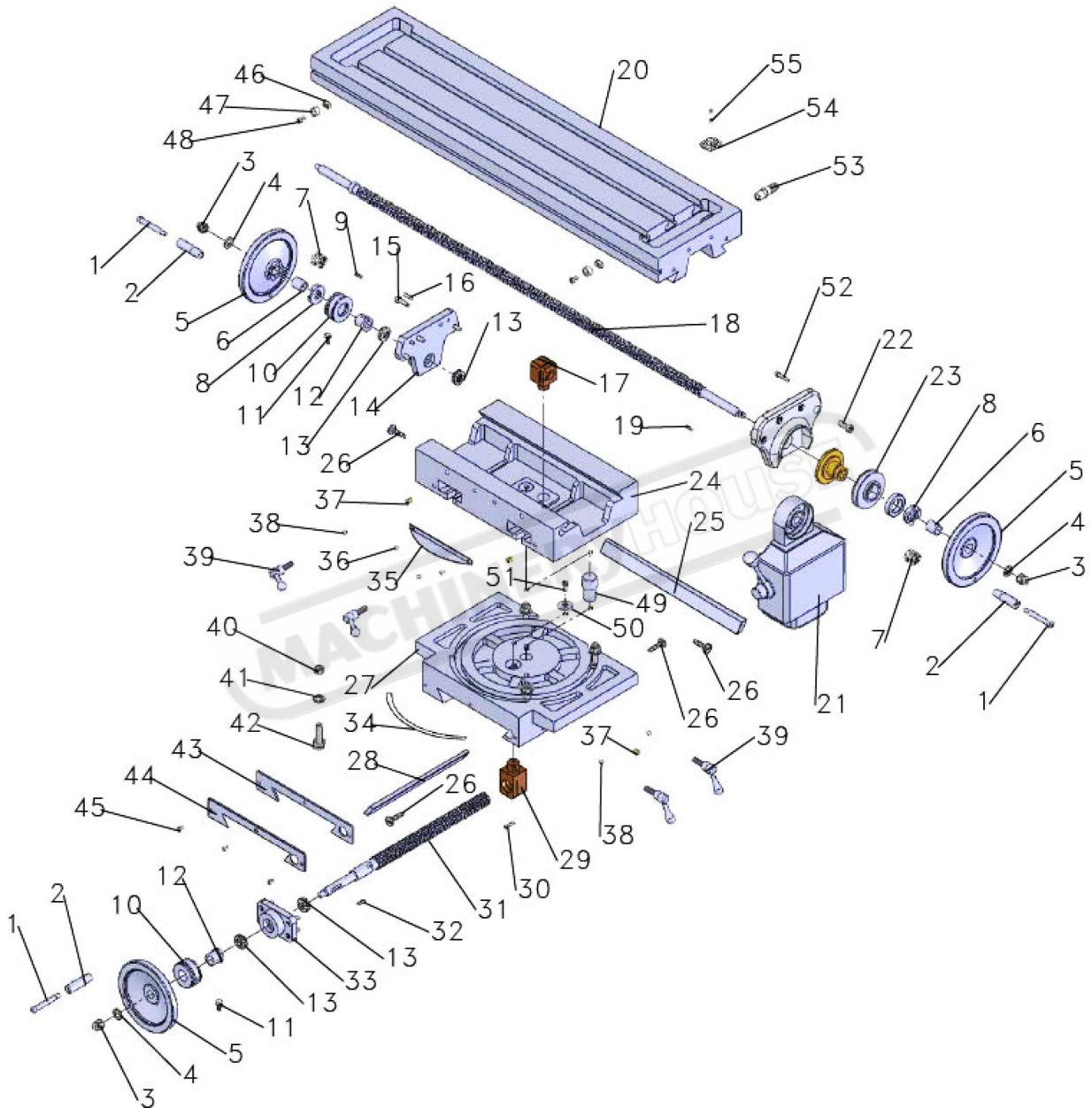

OPERATION MANUAL

B: SWIVEL TABLE PARTS LIST HM-54GV

No.	Description	Qty.	No.	Description	Qty.
1	HANDLE SPINDLE	3	29	SPECIAL NUT	1
2	TAPER KNOB	3	30	SCREWM5x25	3
3	HEX NUT M12-1.75	3	31	LONG LEAD SCREW	1
4	LOCK WASHER 12MM	3	32	KEY 5x30	1
5	HAND WHEEL	3	33	SUPPORT	1
6	BUSH	2	34	ANGLE RULER	1
7	SPRING	2	35	GUARD	1
8	CONNECT	2	36	SCREWM5X10	2
9	KEY 5x20mm	1	37	OIL CUP 8	4
10	SCALE RING	2	38	CLAMP BLOCK	4
11	CAP SCREW M6-1x16	2	39	CLAMP BOLT M10-1.5x53x25	4
12	COLLAR	2	40	HEX NUT M12	4
13	BALL BEARING 51103	4	41	WASHER 12	4
14	SUPPORT	1	42	T BOLT M12X1.75X42	4
15	CAP SCREW M8x25	6	43	WIPER PLATE	1
16	PIN 6x25mm	2	44	WAY COVER	1
17	SPECIAL NUT	1	45	PHLP HD SCR M5-.8x12	3
18	LONG LEAD SCREW	1	46	SCREW BRACKET	1
19	KEY 5X20mm	1	47	DOG	1
20	TABLE	1	48	CAP SCREW M6-1x16	1
21	POWER FEED	1	49	SHAFT	1
22	CAP SCREW M10x25mm	4	50	WASHER	1
23	SCALE RING	1	51	SCREWM6X30	1
24	ROTARY BRACKET	1	52	PIN 6x25	2
25	GIB	1	53	CONNECT TUBE	1
26	ADJUST SCREW M8-1.25mm	3	54	SPLASH GUARD	1
27	CENTER BASE	1	55	SCREWM4X8	2
28	GIB	1			



OPERATION MANUAL

C: HORIZONTAL SPINDLE PARTS HM-54GV

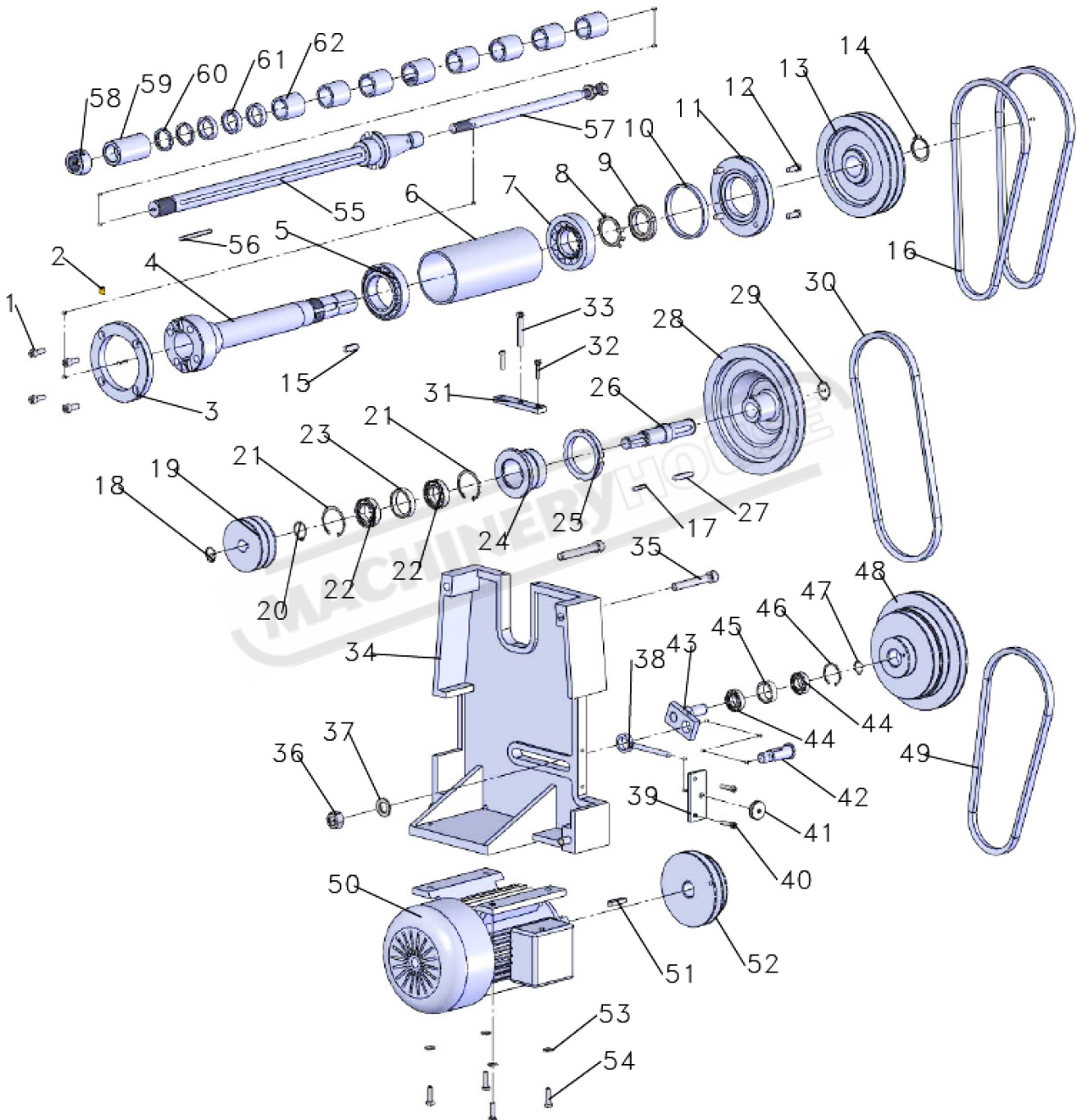

OPERATION MANUAL

C: HORIZONTAL SPINDLE PARTS LIST HM-54GV

No.	Description	Qty.	No.	Description	Qty.
1	CAP SCREW M8-1.25x25	4	40	CAP SCREW M6-1x25	2
2	OIL CUP	1	41	SPECIAL NUT M8-1.25	1
3	COVER	1	42	SMALL SHAFT	1
4	SPINDLE	1	43	CONNECT	1
5	BALL BEARING 32011	1	44	BALL BEARING 6003	2
6	COLLAR	1	45	COLLAR	1
7	BALL BEARING 30308	1	46	INT RETAINING RING 35MM	1
8	FLAT WASHER 39MM	1	47	EXT RETAINING RING 17MM	1
9	SLOTTED LOCK NUT M39X1.5	1	48	PULLEY	1
10	SPECIAL WASHER 90x4	1	49	V-BELT A800	1
11	COVER	1	50	MOTOR	1
12	CAP SCREW M8-1.25x25	4	51	KEY 8X45	1
13	SPINDLE PULLEY	1	52	MOTOR WHEEL	1
14	RETAINING RING	1	53	LOCK WASHER 8MM	4
15	KEY 10X8X30	1	54	HEX BOLT M8-1.25x30	4
16	V-BELT A838	2	55	HORIZONTAL ARBOR	1
17	KEY 6X30	1	56	KEY	1
18	EXT RETAINING RING 20	1	57	HORIZONTAL ARBOR	1
19	WHEEL	1	58	ARBOR NUT	1
20	EXT RETAINING RING 25	1	59	ARBOR SLEEVE	1
21	INT RETAINING RING 47MM	2	60	ARBOR SPACER	2
22	BALL BEARING 6005	2	61	COLLAR	3
23	COLLAR	1	62	ARBOR SLEEVE	8
24	COLLAR	1			
25	SPECIAL NUT M64X2	1			
26	SMALL SHAFT	1			
27	KEY 8X40	1			
28	PULLEY	1			
29	EXT RETAINING RING 25MM	1			
30	V-BELT A864	1			
31	SUPPORT	1			
32	CAP SCREW M6-1x25	2			
33	HEX BOLT M8-1.25x60	1			
34	MOTOR BASE	1			
35	CAP SCREW M12-1.75x85	4			
36	HEX NUT M16-2	1			
37	FLAT WASHER 16MM	1			
38	ADJUST SCREW M8-1.25	1			
39	SUPPORT	1			

D: SPINDLE BOX PARTS HM-54GV

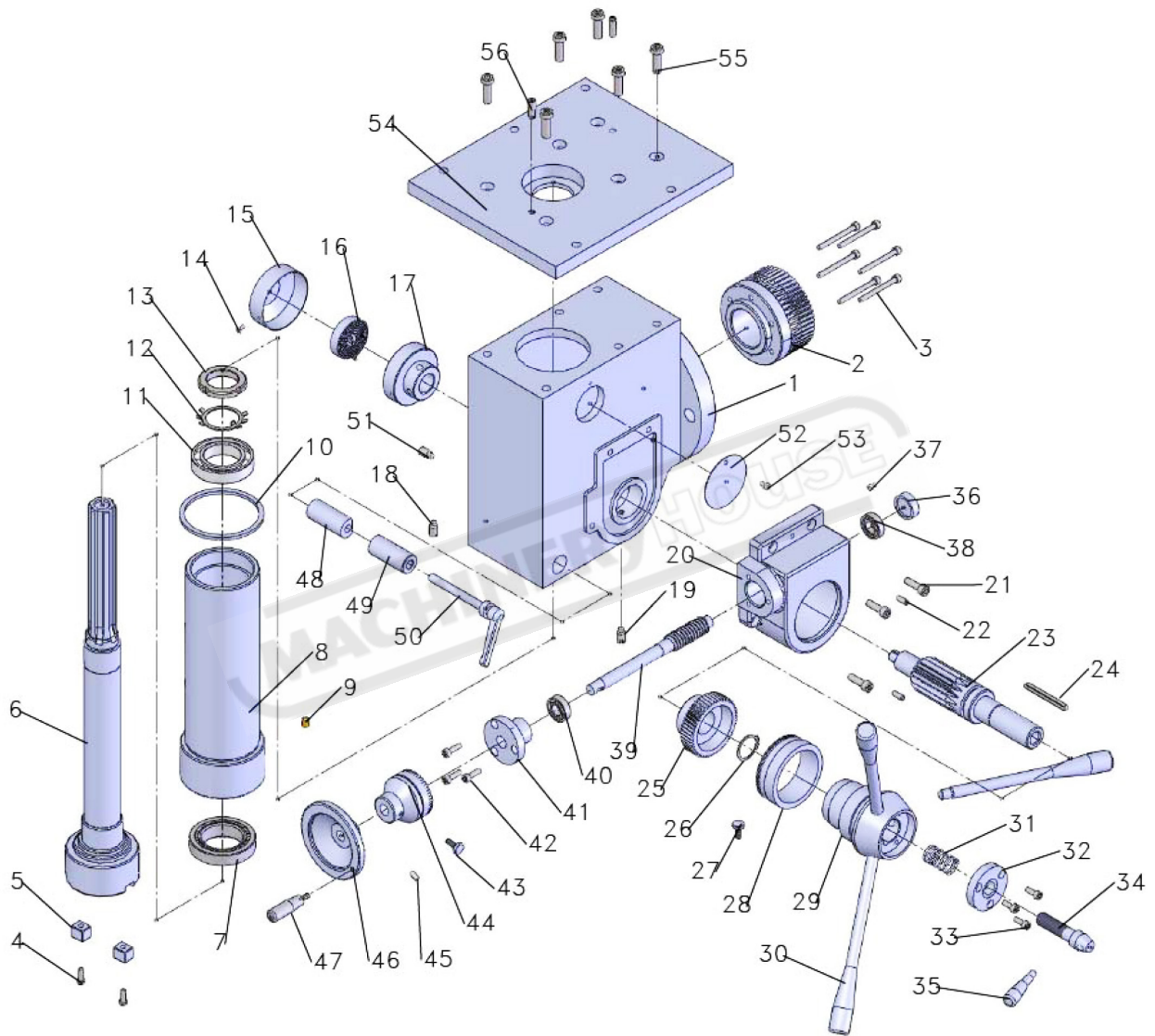

OPERATION MANUAL

D: SPINDLE BOX PARTS LIST HM-54GV

No.	Description	Qty.	No.	Description	Qty.
1	SPINDLE BOX	1	40	BALL BEARING 6002	1
2	GEAR	1	41	COVER	1
3	SCREWM6X75	6	42	SCREWM6-1x20	3
4	SCREWM6X16	2	43	CAP SCREW M6-1x16	1
5	FIXED KEY	2	44	SCALE RING	1
6	SPINDLE	1	45	SCREWM6-1x12	1
7	BALL BEARING 32010	1	46	HANDLE WHEEL	1
8	SLEEVE	1	47	HANDLE	1
9	OIL CUP	1	48	CLAMP BLOCK	1
10	RUBBER WASHER 90MM	1	49	CLAMP BLOCK	1
11	BALL BEARING 6009	1	50	CLAMP HANDLE	1
12	LOCK WASHER 40	1	51	SET SCREW M10X10	2
13	LOCK NUT M40X1.5	1	52	BAFFLE	1
14	CAP SCREW M4X8	1	53	SCREWM5X10	1
15	SPRING CAP	1	54	HEAD BOX COVER	1
16	SPRING PLATE	1	55	SCREWM10X30	6
17	SPRING BASE	1	56	PIN 8X25	2
18	SET SCREW M8X16	1			
19	SET SCREW M8X16	1			
20	HANDL WHEEL GEAR BOX	1			
21	SCREWM8X25	3			
22	PIN 6X25	2			
23	FEED SHAFT	1			
24	KEY 8X38	1			
25	HELICAL GEAR	1			
26	EXT RETAINING RING 30	1			
27	CAP SCREW M6-1x16	1			
28	SCALE RING	1			
29	HANDLE BRACKET HUB	1			
30	HANDLE BAR	2			
31	COMPRESSION SPRING	1			
32	COVER	1			
33	CAP SCREW M6X16	3			
34	HANDLE SEAT M16X2	1			
35	HANDLE BAR	1			
36	COVER	1			
37	SCREWM6X12	1			
38	BALL BEARING 6002	1			
39	WORM	1			

E: GEAR HEAD PARTS HM-54GV

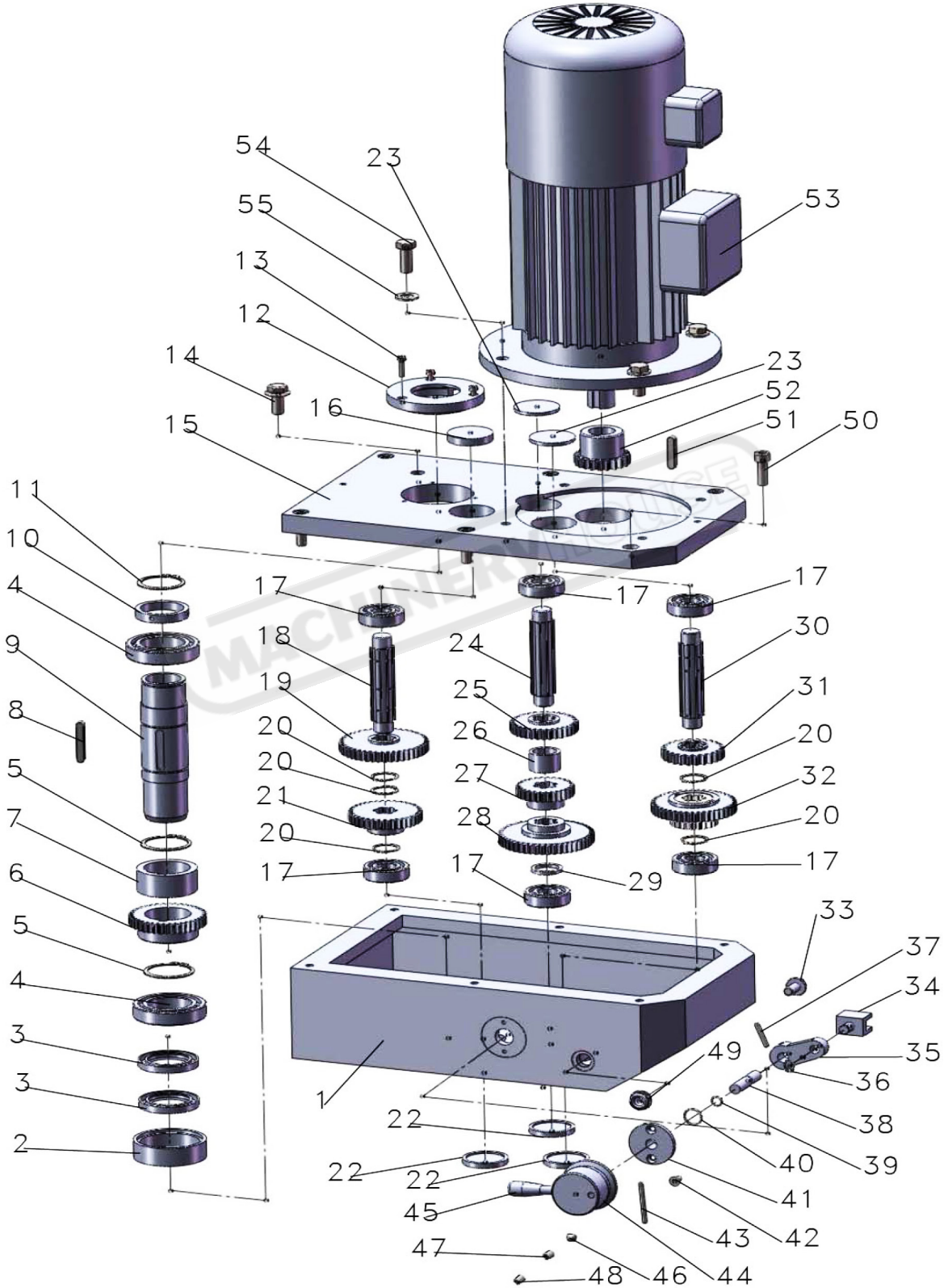

OPERATION MANUAL

E: GEAR HEAD PARTS LIST HM-54GV

No.	Description	Qty.	No.	Description	Qty.
1	GEAR CASE	1	40	RUBBER RING 20X2	1
2	COLLAR	1	41	COVER	1
3	OIL SEAL FB45X62X8	2	42	SCREW5X12	2
4	BALL BEARING 6009	2	43	PIN 5X50	1
5	EXT RETAINING RING 45	2	44	HANDLE SEAT	1
6	GEAR	1	45	HANDLE	1
7	COLLAR	1	46	STEEL BALL 6	1
8	KEY 8X50	1	47	SPRING	1
9	SHAFT	1	48	SET SCREW	1
10	SPEED MEASUREMENT	1	49	OIL POINTER	1
11	EX RETAINING RING 45	1	50	CAP HEAD SCREW	6
12	COLLAR	1	51	KEY 8X40	1
13	SCREWM5X15	3	52	GEAR	1
14	HEX BOLT M16X1.5	1	53	MOTOR	1
15	BOX COVER	1	54	SCREWM12X30	4
16	COVER	1	55	WASHER 12	4
17	BALL BEARING 6204	6			
18	DRIVING SHAFT	1			
19	GEAR	1			
20	EX RETAINING RING 25	5			
21	GEAR	1			
22	COVER	3			
23	COVER	2			
24	DRIVING SHAFT	1			
25	GEAR	1			
26	COLLAR	1			
27	GEAR	1			
28	GEAR	1			
29	RING	1			
30	DRIVING SHAFT	1			
31	GEAR	1			
32	GEAR	1			
33	HEX BOLT M10X1	1			
34	LIFT FORK	1			
35	ROCKER ARM	1			
36	EX RETAINING RING 10	1			
37	PIN 5X30	1			
38	SMALL SPINDLE	1			
39	RUBBER RING 12X2	1			

D: ELECTRICAL DIAGRAM HM-54GB

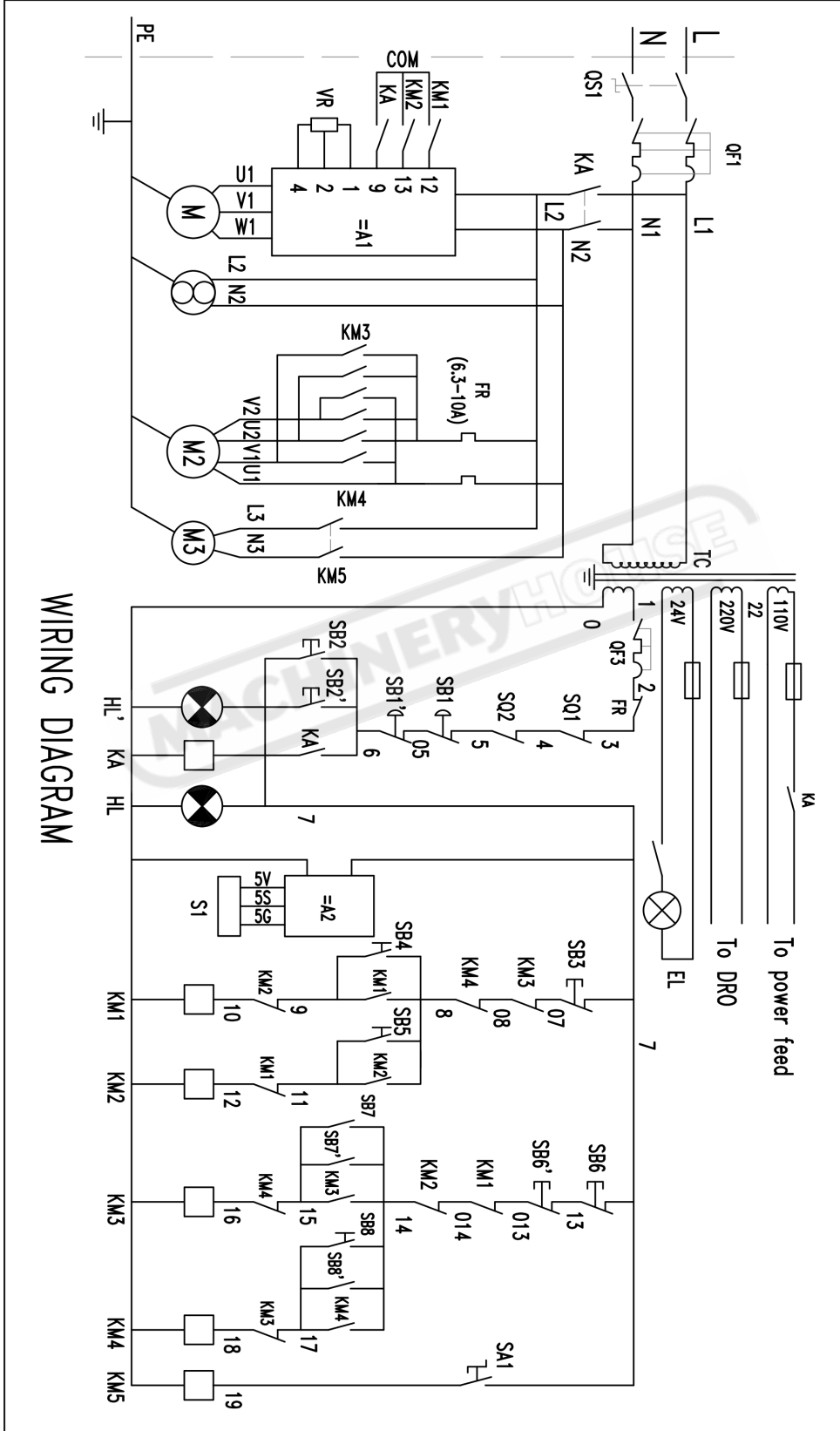



WARNING

General Machinery Safety Instructions

Machinery House
requires you to read this entire Manual before using this machine.

- 1. Read the entire Manual before starting machinery.** Machinery may cause serious injury if not correctly used.
- 2. Always use correct hearing protection when operating machinery.** Machinery noise may cause permanent hearing damage.
- 3. Machinery must never be used when tired, or under the influence of drugs or alcohol.** When running machinery you must be alert at all times.
- 4. Wear correct Clothing.** At all times remove all loose clothing, necklaces, rings, jewelry, etc. Long hair must be contained in a hair net. Non-slip protective footwear must be worn.
- 5. Always wear correct respirators around fumes or dust when operating machinery.** Machinery fumes & dust can cause serious respiratory illness. Dust extractors must be used where applicable.
- 6. Always wear correct safety glasses.** When machining you must use the correct eye protection to prevent injuring your eyes.
- 7. Keep work clean and make sure you have good lighting.** Cluttered and dark shadows may cause accidents.
- 8. Personnel must be properly trained or well supervised when operating machinery.** Make sure you have clear and safe understanding of the machine you are operating.
- 9. Keep children and visitors away.** Make sure children and visitors are at a safe distance for you work area.
- 10. Keep your workshop childproof.** Use padlocks, Turn off master power switches and remove start switch keys.
- 11. Never leave machine unattended.** Turn power off and wait till machine has come to a complete stop before leaving the machine unattended.
- 12. Make a safe working environment.** Do not use machine in a damp, wet area, or where flammable or noxious fumes may exist.
- 13. Disconnect main power before service machine.** Make sure power switch is in the off position before re-connecting.
- 14. Use correct amperage extension cords.** Undersized extension cords overheat and lose power. Replace extension cords if they become damaged.
- 15. Keep machine well maintained.** Keep blades sharp and clean for best and safest performance. Follow instructions when lubricating and changing accessories.
- 16. Keep machine well guarded.** Make sure guards on machine are in place and are all working correctly.
- 17. Do not overreach.** Keep proper footing and balance at all times.
- 18. Secure workpiece.** Use clamps or a vice to hold the workpiece where practical. Keeping the workpiece secure will free up your hand to operate the machine and will protect hand from injury.
- 19. Check machine over before operating.** Check machine for damaged parts, loose bolts, Keys and wrenches left on machine and any other conditions that may effect the machines operation. Repair and replace damaged parts.
- 20. Use recommended accessories.** Refer to instruction manual or ask correct service officer when using accessories. The use of improper accessories may cause the risk of injury.
- 21. Do not force machinery.** Work at the speed and capacity at which the machine or accessory was designed.
- 22. Use correct lifting practice.** Always use the correct lifting methods when using machinery. Incorrect lifting methods can cause serious injury.
- 23. Lock mobile bases.** Make sure any mobile bases are locked before using machine.
- 24. Allergic reactions.** Certain metal shavings and cutting fluids may cause an allergic reaction in people and animals, especially when cutting as the fumes can be inhaled. Make sure you know what type of metal and cutting fluid you will be exposed to and how to avoid contamination.
- 25. Call for help.** If at any time you experience difficulties, stop the machine and call you nearest branch service department for help.



Milling Machine Safety Instructions

Machinery House
requires you to read this entire Manual before using this machine.

- 1. Maintenance.** Make sure the mill is turned off and disconnect from the main power supply and make sure all moving parts have come to a complete stop before any inspection, adjustment or maintenance is carried out.
- 2. Mill Condition.** Mill must be maintained for a proper working condition. Never operate a mill that has damaged or worn parts. Scheduled routine maintenance should be performed on a scheduled basis.
- 3. Leaving a Mill Unattended.** Always turn the mill off and make sure all moving parts have come to a complete stop before leaving the mill. Do not leave mill running unattended for any reason.
- 4. Avoiding Entanglement.** Remove loose clothing, belts, or jewelry items. Never wear gloves while machine is in operation. Tie up long hair and use the correct hair nets to avoid any entanglement with the mill spindle or moving parts.
- 5. Chuck key safety.** Always remove your chuck key, draw bar wrench, and any service tools immediately after use. Chuck keys left in the chuck can cause serious injury.
- 6. Understand the machines controls.** Make sure you understand the use and operation of all controls.
- 7. Tooling selection & holding.** Always use the correct cutting tool for the job you are milling. Make sure it is sharp and held firmly in place.
- 8. Cutting Tool inspection.** Inspect Drill and end mills for sharpness, chips, or cracks before use. Replace any cutting tools immediately if dull, chipped or cracked. Handle new cutting tools with care. Cutting edges are very sharp and can cause lacerations.
- 9. Reversing the spindle.** Make sure the spindle has come to a complete stop before changing the direction of the spindle. Do not slow or stop the spindle by using your hand.
- 10. Stopping the spindle.** Do not slow or stop the spindle by using your hand.
- 11. Speed selection.** Select the appropriate speed for the type of work, material, and tool bit. Allow the mill to reach full speed before beginning a cut.
- 12. Clearing chips.** Always use a brush to clear chips. Never clear chips when the mill is running.
- 13. Power outage.** In the event of a power failure during use of the mill, turn off all switches to avoid possible sudden start up once power is restored.
- 14. Clean work area.** Keep the area around the mill clean from oil, tools and chips.
- 15. Tilting head.** Use an assistant to help support the head correctly. Make sure bolts that secure the head for tilting are not loosened to much as head can slip and cause serious injury. Please refer to Mill head Tilting Instructions for correct procedure.
- 16. Call for help.** If at any time you experience difficulties, stop the machine and call your nearest branch service department for help.

PLANT SAFETY PROGRAM

NEW MACHINERY HAZARD IDENTIFICATION, ASSESSMENT & CONTROL

Milling Machine

Developed in Co-operation Between A.W.I.S.A and Australia Chamber of Manufactures
This program is based upon the Safe Work Australia, Code of Practice - Managing Risks of Plant in the Workplace (WHSA 2011 No10)



Item No.	Hazard Identification	Hazard Assessment	Risk Control Strategies <small>(Recommended for Purchase / Buyer / User)</small>
A	ENTANGLEMENT	HIGH	Eliminate, avoid loose clothing / Long hair etc.
B	CRUSHING	LOW	Secure & support workpiece on mill table.
B	CRUSHING	HIGH	Mill head tilting adjustment - please refer to mill head tilting instruction sheet for correct procedure.
C	CUTTING, STABBING, PUNCTURING	MEDIUM	Incorrect adjustment may result in the head becoming detached and a crushing hazard Isolate power to machine prior to any checks or maintenance being carried out. Do not adjust or clean machine until the machine has fully stopped.
D	SHEARING	MEDIUM	Make sure all guards are secured shut when machine is on. Isolate power to machine prior to any checks or maintenance.
F	STRIKING	MEDIUM	Ensure tooling is secure in chuck. Wear safety glasses. Stand clear of moving parts on machine. Remove all loose objects around moving parts. Ensure correct spindle direction when milling.
H	ELECTRICAL	MEDIUM	All electrical enclosures should only be opened with a tool that is not to be kept with the machine. Machine should be installed & checked by a Licensed Electrician.
M	HIGH TEMPERATURE	LOW	Wear appropriate protective clothing to prevent hot swarf.
O	OTHER HAZARDS, NOISE.	LOW	Wear hearing protection as required.
Plant Safety Program to be read in conjunction with manufactures instructions			



www.machineryhouse.com.au



www.machineryhouse.co.nz

Authorised and signed by:
Safety officer: 
Manager: 

Revised Date: 12th March 2012